

M8

SERIES

by

MUSICAL FIDELITY

DESIGNED IN ENGLAND

Installation Guide

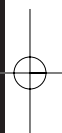
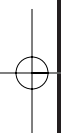

DUAL MONO INTEGRATED AMPLIFIER | M8xi

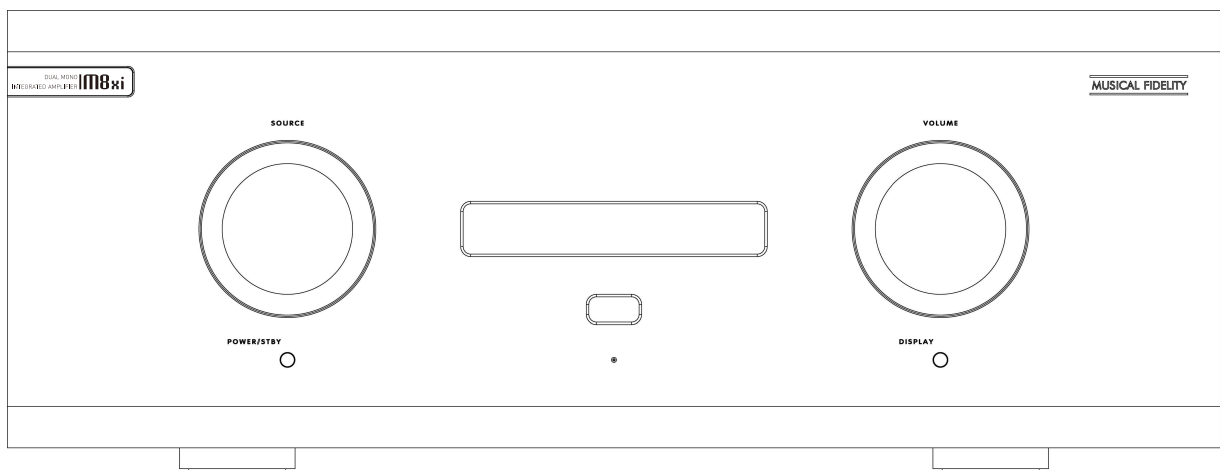

Instructions for use

Thank you for purchasing the Musical Fidelity M8xi dual mono integrated amplifier.

This amplifier is designed with high quality reproduction of single ended and balanced sources in mind.

Two sets of balanced (XLR) inputs take care of balanced audio for the best in signal to noise, transient reproduction and dynamic range from balanced sources.

Units with single-ended (RCA) inputs and outputs are catered for with 4 selectable RCA inputs, and two sets of outputs, one fixed for headphone amplifier, recording etc, the other is the main controlled output which can be used for bi-amping or stereo input subwoofers.

The M8xi has been designed to mix-and-match input/output signal types and works as a single ended to balanced (or vice versa) converting preamplifier. It is also designed to allow use of both balanced and single ended inputs or outputs simultaneously, if required. All conversions are carried out automatically within the unit, all that needs to be done is choose and connect the correct input and output leads.

The volume control is a dual laser-trimmed stepped attenuator giving 0.5dB steps of perfect matching, allowing precise stereo imaging and ultra-low noise and distortion even at the lowest levels.

Balanced preamp outputs are now also available, allowing connection of balanced input power amplifiers to realise a balanced cable system from source to speakers.

The M8xi is designed to be partnered with present and future M8 or M6 series products or alternatively, may be used with any other high quality hi-fi components. This combination yields one of the best high-fidelity systems available at any price.

Used properly and carefully, it should give many years of outstanding musical reproduction.

Dust regularly with a soft duster or soft brush; but be careful when using cleaning or polishing agents - they may harm the surface finish.

If there are any questions about the audio system, please consult the dealer who is there to help and advise.

Section	Page
Safety Information	3
– Mains plug (UK only)	
– Modification warning	
General advice	4
– Installation precautions & user information	
Disposal information	5
– EU disposal information	
Installation	6
– Introduction, cleaning, installation, power connections, audio connections	
Facilities and connections	7
– Illustrations, main unit front & rear panels	
Remote control handset	8
– Operation and illustration	
Operation	9
– Starting	
– Volume	
– Mute	
– CD	
– TUNER	
– AUX1	
– AUX2/HT	
– XLR BALANCED 1 & 2	
– COAX 1 & 2	10
– OPTICAL 1 & 2	
– USB	
Problems?	11
– Basic fault finding	
Specifications	12
Manual history	13

IMPORTANT! (U.K. only)

This unit is supplied in the U.K. with mains lead fitted with a moulded 13 amp plug. If, for any reason, it is necessary to remove the plug, please remove the fuse holder and dispose of the plug safely, out of reach of children.

It must not be plugged into a mains outlet.

The wires in the mains lead supplied with this appliance are coloured in accordance with the following code:

Green and yellow	Earth
Blue.....	Neutral
Brown	Live

WARNING – This appliance MUST be earthed

As the colours of the wires of the mains lead of this appliance may not correspond with the coloured markings identifying the terminals in the plug, proceed as follows:

- The wire which is coloured green-and-yellow must be connected to the terminal in the plug which is marked with the letter E or coloured green or green-and-yellow, or by the earth symbol: 
- The wire which is coloured brown must be connected to the terminal which is marked with the letter L or coloured red.
- The wire which is coloured blue must be connected to the terminal which is marked with the letter N or coloured black.
- If connecting to a BS1363 plug, a 13 amp fuse must be used.

WARNING:
ANY MODIFICATIONS TO THIS PRODUCT NOT EXPRESSLY APPROVED BY MUSICAL FIDELITY WHO IS THE PARTY RESPONSIBLE FOR STANDARDS COMPLIANCE COULD VOID THE USER'S AUTHORITY TO OPERATE THIS EQUIPMENT.

Installation precautions & user information

This new M8xi Integrated Amplifier is designed and built to provide trouble-free performance, but as with all electronic devices it is necessary to observe a few precautions:

- This unit features a BRIDGED speaker output and should NOT be grounded on either speaker output terminal as both terminals are effectively “hot”, i.e. carrying high current signals. Please check if using any active “sub”, electrostatic, or other non-standard speaker types or configurations (that could be potentially grounded) with the M8xi. Take special care when bi-amping that the speaker high and low frequency elements within speaker are completely isolated before switching on power. Consult speaker manual or manufacturer, if there is any doubt.
- Heed all warnings shown on the back of the product.
- Only connect the M8xi to a mains outlet having the same voltage as marked at the back of the unit.
- Always ensure that when disconnecting and reconnecting your audio equipment the mains supply is switched off.
- Position the mains lead and signal interconnects where they are not likely to be walked on or trapped by items placed on them.
- Do not use near water, or place water-filled containers on the M8xi, for example, a flower vase or potted plants. **If water does spill inside, immediately pull out the mains plug from the wall socket and inform your dealer, who should then check the unit before further use. Entry of liquid into the M8xi is dangerous and may cause electric shock or fire hazard.**
- Do not place the unit near direct heat sources such as radiators, direct sunlight or other equipment.
- Do not remove any covers or try to gain access to the inside. There are no internal adjustments or fuses you can replace yourself. Refer all service work to an authorised Musical Fidelity agent.
*** Note: Unauthorised opening of the equipment will invalidate any warranty claim.**
- Dust regularly with a soft cloth or soft brush but be careful when using cleaning or polishing agents - they may harm the surface finish. Before cleaning the unit, switch off power at the mains switch and remove the mains plug from the wall socket.

The electronics in modern hi-fi equipment is complex and may, therefore, be adversely affected or damaged by lightning. For protection of the audio system during electrical storms, remove the mains plugs.

If after-sales service is required, to help the dealer identify the M8xi please quote the serial number located on the rear panel of the unit.



DISPOSAL

The crossed out wheeled bin label that appears on the back panel of the product indicates that the product must not be disposed of as normal household waste. To prevent possible harm to the environment please separate the product from other waste to ensure that it can be recycled in an environmentally safe manner. Please contact local government office or retailer for available collection facilities.



DISPOSITION

La poubelle sur roulettes barrées X, qui apparaît en logo sur le panneau arrière du produit, indique que celui-ci ne doit pas être traité comme un déchet domestique commun. Afin de protéger l'environnement, ce produit électronique devra être géré séparément et donc recyclé selon les nouvelles normes Européennes Rohs concernant les déchets d'appareils électroniques. Prière de contacter les services concernés gouvernementaux ou votre point de vente pour l'élimination et l'enlèvement de déchets électroniques équipés de composants électroniques.



DISPOSAL

La etiqueta cruzada hacia fuera del compartimiento que aparece en el panel trasero del producto indica que el producto no se debe reciclar como basura normal de la casa. Para prevenir daños posible al ambiente separe por favor el producto de otras basura para asegurarse de que puede ser reciclada de una manera ambientalmente segura. Entre en contacto por favor a su oficina gubernamental local o a su minorista para las instalaciones disponibles de la colección.



RIFIUTI

L'etichetta del cassonetto barrato riportato sul retro dell'apparecchio indica che il prodotto non deve essere smaltito tramite la procedura normale di smaltimento dei rifiuti domestici. Per evitare eventuali danni all'ambiente, separare questo prodotto da altri rifiuti domestici in modo che possa venire riciclato in base alle procedure di rispetto ambientale. Per maggiori dettagli sulle aree di raccolta disponibili, contattate l'ufficio govenativo locale od il rivenditore del prodotto.



FACHGERECHTE ENTSORGUNG:

Das auf der Geräterückseite angebrachte Label deutet darauf hin, dass das Produkt nicht mit konventionellem Hauskehrichrt entsorgt werden darf. Um Schäden und Verschmutzungen an Umwelt und Mensch zu vermeiden, muss das Produkt fachgerecht entsorgt und von anderem Abfall getrennt werden. Wenden Sie sich bei Fragen hierzu an Ihren Fachhändler oder an eine öffentliche Informationsstelle.



AFVAL

Het label op de achterzijde van dit apparaat, een afvalbak op wielen met een kruis doorgehaald, geeft aan dat dit apparaat niet samen met gewoon huishoudafval mag worden weggegooid. Om mogelijke schade aan onze leefomgeving te voorkomen dient dit apparaat, gescheiden van gewoon huishoudelijk afval, te worden afgevoerd zodat het op een milieuvriendelijke manier kan worden gerecycled. Neem voor beschikbare inzamelplaatsen contact op met uw gemeentelijke reinigingsdienst of met uw elektronica leverancier.



HÄVITTÄMINEN

Yliüksattua jäteastiaa kuvaava tarra tuotteen takalevyssä kertoo, että tuotetta ei saa käsitellä normaalina talousjätteenä. Ympäristön suojelemiseksi on tuote pidettävä erillään muusta jätteestä ja se on kierrätettävä ekologisesti kestävällä tavalla. Ota yhteyttä laitteen myyjään tai Pirkanmaan Ympäristökeskukseen lähimmän kierrätyskeskuksen löytämiseksi.



AFSKAFNING

Logoet med en skraldespand med kryds over på bagsiden af apparatet indikerer at dette produkt ikke må kasseres som normal husholdningsaffald. For at forebygge mulig skade på miljøet, bedes De separere dette produkt fra andet affald, og sikre at det bliver genbrugt på en miljørigtig måde. Kontakt venligst de lokale myndigheder eller din forhandler for oplysning om nærmeste tilgængelige opsamlingssted for elektronikaffald.



ΔΙΑΔΙΚΑΣΙΑ ΑΠΟΡΡΙΨΗΣ

ΤΟ ΣΗΜΑ ΜΕ ΤΟΝ ΔΙΑΓΕΓΡΑΜΜΕΝΟ ΤΡΟΧΗΛΑΤΟ ΚΑΔΟ ΑΠΟΡΡΙΜΑΤΩΝ ΣΤΗΝ ΠΙΣΩ ΟΨΗ ΤΟΥ ΜΗΧΑΝΗΜΑΤΟΣ

ΔΗΛΩΝΕΙ ΟΤΙ ΤΟ ΠΡΟΙΟΝ ΑΥΤΟ ΔΕΝ ΠΡΕΠΕΙ ΝΑ ΔΙΑΧΕΙΡΙΣΘΕΙ ΣΑΝ ΣΥΝΗΘΙΣΜΕΝΟ ΟΙΚΙΑΚΟ ΑΠΟΒΛΗΤΟ. ΠΡΟΣ ΑΠΟΦΥΓΗ ΕΝΔΕΧΟΜΕΝΗΣ ΕΠΙΒΑΡΥΝΣΗΣ ΤΟΥ ΠΕΡΙΒΑΛΛΟΝΤΟΣ, ΞΕΧΩΡΙΣΤΕ ΤΟ ΠΡΟΙΟΝ ΑΠΟ ΤΑ ΆΛΛΑ ΑΠΟΡΡΙΜΑΤΑ ΩΣΤΕ ΝΑ ΕΞΑΣΦΑΛΙΣΘΕΙ Η ΑΝΑΚΥΚΛΩΣΗ ΤΟΥ ΜΕ ΤΟΝ ΠΡΕΠΟΝΤΑ ΤΡΟΠΟ. ΠΑΡΑΚΑΛΟΥΜΕ ΝΑ ΕΠΙΚΟΙΝΩΝΗΣΕΤΕ ΜΕ ΤΗΝ ΤΟΠΙΚΗ ΥΠΗΡΕΣΙΑ ΑΝΑΚΥΚΛΩΣΗΣ Η ΜΕ ΤΟ ΚΑΤΑΣΤΗΜΑ ΑΓΟΡΑΣ ΓΙΑ ΠΕΡΙΣΣΟΤΕΡΕΣ ΛΕΠΤΟΜΕΡΕΙΕΣ.

Position the M8xi on a stable, horizontal surface where there is no risk of it being knocked or subjected to vibration such as from loudspeakers.

Try to route mains leads well away from input leads and keep input leads as far away from speaker leads as possible.

Power Connections

The M8xi is supplied with a C19 IEC mains cable which plugs into the IEC socket at the back of the unit (see page 7)

Audio Connections

RCA Inputs: Connect all RCA single-ended sources to relevant analogue inputs (see page 7 for more information). Use good quality fully connected (signal and ground) coaxial phono cables for all RCA signal connections.

XLR Balanced Inputs: Connect any XLR balanced source to desired balanced analogue inputs (see page 7 for more information). Use good quality fully connected (signals and ground) balanced XLR cables for all XLR signal connections.

USB input: Connect USB "A" to "B" cable between USB input and computer (laptop, desktop, tablet or any other suitable USB audio compatible "host").

COAX inputs: Connect RCA digital source to digital input RCA socket. Use a good quality fully connected (signal and ground) coaxial digital cable, for optimum signal transfer.

OPTICAL inputs: Connect optical digital source to optical input socket. Use a good quality "Toslink" cable, for optimum signal transfer.

RCA Outputs: Connect all RCA single-ended power amplifier(s) to RCA analogue outputs (see page 7 for more information). Use good quality fully connected (signal and ground) coaxial phono cables for all RCA signal connections.

XLR Outputs: Connect any XLR balanced power amplifier(s) to XLR analogue outputs (see page 7 for more information). Use good quality fully connected (signals and ground) balanced XLR cables for all XLR signal connections.

Speaker Outputs: Connect loudspeakers to the terminals on the back panel marked as LEFT and RIGHT SPEAKER outputs. For most normal passive speakers this bridged amplifier behaves as any other, however: -

NOTE: Both this amplifier's RED and BLACK speaker terminals carry speaker voltages and currents.

Do not use grounded speakers e.g. some electrostatics or amplified subwoofer "speaker" inputs, as this could short one half of the amplifier to ground and cause potential damage. Check with dealer or speaker manufacturer for advice. Take great care when bi-wiring or bi-amping to not cause inadvertent short circuits.

Trigger connections

Trigger input: Connect trigger output of controlling device to input socket. Use good quality 3.5mm jack cables (fully connected signal and ground) Unit accepts ± 4 to ± 15 V DC trigger inputs. The M8xi can then be switched on or off by remote device(s) connected to its trigger input.

Trigger output: Connect trigger input of controlling device to output socket. Use good quality 3.5mm jack cables (fully connected signal and ground). The M8xi then becomes the main controlling device and its power button will automatically switch on/off all devices thus connected to the trigger output.

Please note: Musical Fidelity currently do not make any interconnecting cables, nor do we endorse any manufacturer's cables. If required, please refer to the Musical Fidelity dealer who can give up to date advice on good quality cables for any setup.

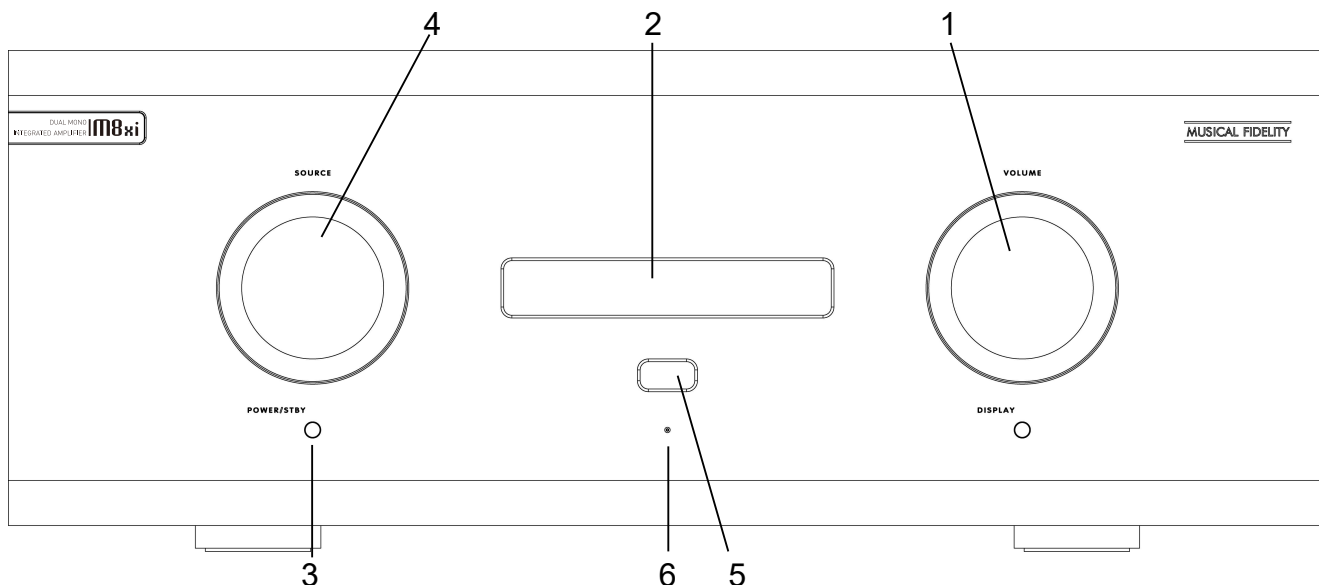

- | | | | |
|---|-------------------------------------|---|---|
| 1 | VOLUME control | 4 | CD, TUNER, AUX1, AUX2/HT, BALANCED 1, BALANCED 2 input selector. |
| 2 | VOLUME display (in decibels) | 5 | IR RECEIVER lens |
| 3 | ON/OFF Button | 6 | POWER LED |

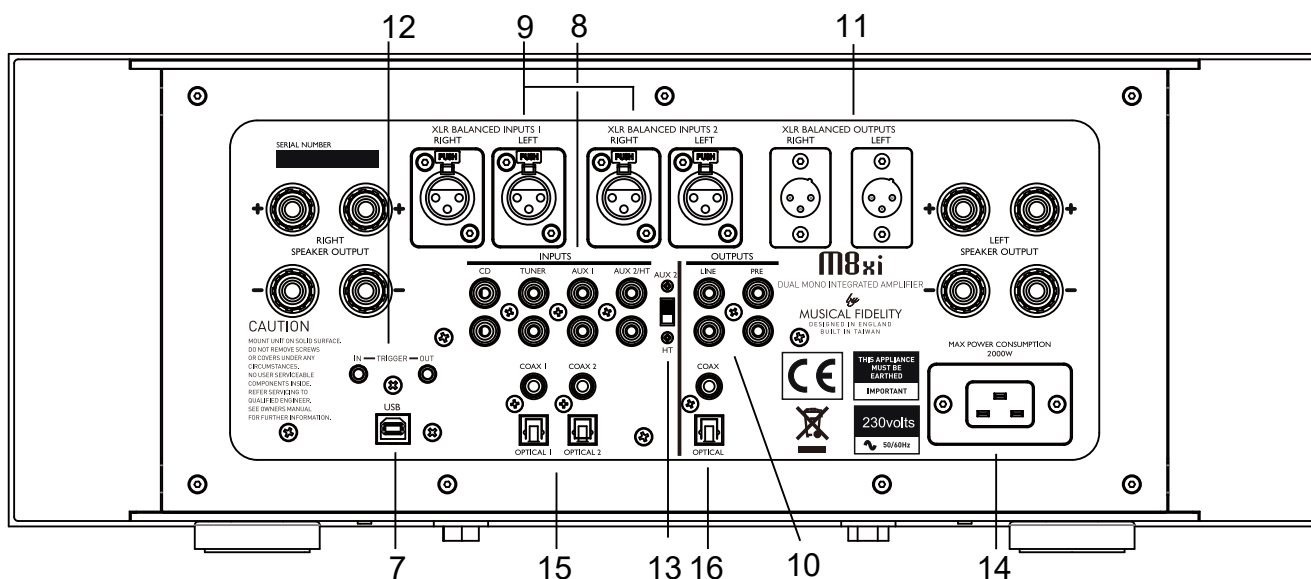

- | | | | |
|----|---|----|---|
| 7 | USB input | 13 | HT/AUX Selector for HT/AUX inputs |
| 8 | CD, TUNER, AUX/HT RCA left and right inputs | 14 | IEC MAINS INPUT |
| 9 | XLR BALANCED 1 & 2 right and left inputs | 15 | OPTICAL&COAX digital input 1&2 |
| 10 | RCA main outputs left and right | 16 | OPTICAL&COAX digital output |
| 11 | XLR BALANCED PRE outputs left and right | | |
| 12 | TRIGGER IN/OUT 3.5mm mono jack sockets | | |

XLR Balanced input and output lead connections:

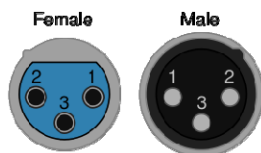

(for reference, no XLR signal leads supplied)

Pin functions:

- 1 Ground (cable shield)
- 2 Normal polarity ("hot" or "+")
- 3 Inverted polarity ("cold" or "-")

The universal remote control shown below enables functions from this and related units to be operated from a convenient distance.

Equivalent buttons on the remote control have the same functions as those on the front panel of the unit. Other functions are only available by remote control.

As the handset uses an invisible infra-red light beam, the front edge must be pointed directly towards the receiver window at the front of the player, without visual obstruction between them.

If the range of the remote control greatly decreases, replace the batteries with new ones. Do not mix old and new batteries – two are required, size AAA, LR03 or SUM-4.

Please dispose of used batteries in accordance to local regulations.

REPEAT – repeats whole disk or selected tracks

SHUFFLE – plays back tracks in random order

INTRO – plays first 10 seconds of each track

A/B sets repeat start/end to repeat section of track

PROGRAM – programs selection and order of tracks

CHECK – check pre-programmed tracks

TIME – displays track time/time remaining

◀◀ - back to beginning/previous track

◀◀ - search back through track

|| / ▶ - pause/play

DISPLAY – CD display brightness

▶▶ - forward one track

DISPLAY – dims CD display

Amplifier section

VOL (-) – reduces volume

USB/Phono - selects USB/Phono input

CD - selects CD input (on amplifier)

AUX1- selects AUX1 input

AUX2/HT - selects AUX2/HT input

BAL 1 - selects balanced1 input

BAL 2 - selects balanced 2 input

COAX 1 – selects COAX 1 input

COAX 2 – selects COAX 2 input

CD Player Digital input section

CD – selects internal CD player

SPDIF – selects COAX input

OPTICAL – selects OPTICAL input

OPTICAL 2 – selects OPTICAL 2 input

AES/USB - selects AES/USB input



MUTE - mutes outputs (until pressed again).

0-9 Buttons – Used to select CD track numbers

CLEAR – clears selected pre-programmed track

STOP – Stop playing/Eject CD

▶▶ - search forward through track

VOL (+) increases volume

TUNER - selects TUNER input

TAPE/AUX4 selects tape/AUX4 (where present)

BAL 1 - selects balanced1 input

BAL 2 - selects balanced 2 input

OPTICAL 1 – selects OPTICAL 1 input

OPTICAL 2 – selects OPTICAL 2 input

DISPLAY – amplifier display brightness

Starting

Once all connections are made, switch on the unit, using the **POWER** button front of the unit. Outputs are muted for about 5 seconds, so no sound will be heard. Once the 5 seconds is up, unit is settled, and ready for use.

Volume

The volume should be adjusted for normal listening levels. This is done by turning the volume up/down knob on the front panel. Adjusting the volume can also be achieved using the remote handset, using the volume up/down buttons (see page 8).

The display shows the current dB step of the laser-trimmed electronic attenuator. The display increments by accurate 0.5dB steps.

Mute (Remote Control only)

The output may be muted by use of the **MUTE** button on the remote. Press once, and **MUTE** will display indicating muted state. No sound will be heard from the speakers.

To return to listening; simply press the **MUTE** button again so **MUTE** is no longer displayed.

CD input

To use the **CD** input, connect CD player outputs to the **CD** input RCA sockets (see page 7). Select **CD** input by turning the Source selector.

Selecting the **CD** input can also be achieved by pressing the corresponding button on the remote handsets (see page 8).

TUNER input

To use the **TUNER** input, connect tuner outputs to the **TUNER** input RCA sockets (see page 7). Select **TUNER** input by turning the Source selector.

Selecting the **TUNER** input can also be achieved by pressing the corresponding button on the remote handset (see page 8).

AUX1 input

To use the **AUX1** input, connect tuner outputs to the **AUX1** input RCA sockets (see page 7). Select **AUX1** input by turning the Source selector.

Selecting the **AUX1** input can also be achieved by pressing the corresponding button on the remote handset (see page 8).

AUX2/HT input

To use the **AUX2/HT** input as a standard input, move the **AUX2/HT** switch on the back panel to the **AUX** position. Connect source outputs to the **AUX2/HT** input RCA sockets (see page 7). Select **AUX2/HT** input by turning the Source selection wheel. Selecting the **AUX2/HT** input can also be achieved by pressing the corresponding button on the remote handset, (see page 8).

To use the **AUX2/HT** input as a Home Theatre (preamp bypass) input, move the **AUX/HT** switch on the back panel to the **HT** position. This input is now unaffected by the volume control, allowing volume control on an external Home Theatre processor, with its own volume control, to be used. Connect Home Theatre or other source outputs to the **AUX2/HT** input RCA sockets (see page 7). Select **AUX2/HT** input by turning the Source selection wheel. Selecting the **AUX2/HT** input can also be achieved by pressing the corresponding button on the remote handset, (see page 8).

***IMPORTANT:** Take great care when using the input in HT mode. Ensure that the volume control is turned right down on the HT processor when first setting up. The HT mode is designed for sources which require their own volume control to be used. Connecting sources in HT mode with no volume control could result in damage to hearing and/or speakers due to uncontrolled loud sounds.*

XLR BALANCED 1 & 2 inputs

To use the **BALANCED** inputs, connect balanced source outputs to the **BALANCED 1 or 2** input XLR sockets (see page 7). Select the **BALANCED 1 or 2** input by turning the Source selection wheel. Selecting the **BALANCED 1 & 2** inputs can also be achieved by pressing the corresponding **BAL** button on the remote handset (see page 8).

COAXIAL inputs

To use the **COAXIAL** inputs, connect an external source to the **COAXIAL** inputs (see page 7). Select **COAXIAL input 1 or 2** by turning the Source selection wheel. Selecting the **COAXIAL** inputs can also be achieved by pressing the corresponding **COAX** button on the remote handset (see page 8). All coaxial inputs can accept up to 24 bit 192 kHz PCM stereo data streams.

OPTICAL inputs

To use the **OPTICAL** inputs, connect an external source to the **OPTICAL** inputs (see page 7). Select **OPTICAL input 1 or 2** by turning the Source selection wheel. Selecting the **OPTICAL** inputs can also be achieved by pressing the corresponding **OPT** button on the remote handset (see page 8). The **OPTICAL** input can accept up to 24 bit 96 kHz PCM stereo data streams.

USB input

To use the **USB** input, connect a source to the **USB B** input (see page 7). Select the **USB** input by turning the Source selection wheel. Selecting the **USB** input can also be achieved by pressing the corresponding **USB/Phono** button on the remote handset (see page 8). The **USB** input can accept up to 24 bit 192 kHz PCM.

For best results from USB input

Check mixer and/or computer volume slider settings are set to a suitable level. Normally “full” or “maximum” setting of the slider gives the best results. Lower settings can detract from overall sound due to computer’s internal media player/ mixer attenuation action.

Make sure volume knob on amplifier is turned to usual/comfortable listening position

Select **USB** input on front panel of amplifier.

Play a piece of recorded music from the computer on preferred media player e.g. Windows Media Player or iTunes.

LINE OUT

This is a fixed output signal from the input selected. This includes digital and USB. Volume control has no effect on this output.

It may be used for headphone amplifier (with its own volume control) or recording purposes, for example.

Please note when the amplifier is off this output is disabled along with the rest of the outputs.

Note – the M8xi volume control has no effect on the LINE OUT signal.

PRE OUT (RCA)

This is a variable single ended output signal from the input selected (wether single ended RCA or Balanced XLR).

This allows the unit to be e.g. bi-amped or used as a preamplifier with external power amplifiers.

Please note when the amplifier is off this output is disabled along with the rest of the outputs.

PRE OUT (XLR)

This is a variable balanced output signal from the input selected (wether single ended RCA or Balanced XLR).

This allows the unit to be e.g. bi-amped or used as a preamplifier with external power amplifiers.

Please note when the amplifier is off this output is disabled along with the rest of the outputs.

Trigger input 3.5mm jack

Connect trigger output of controlling device to input socket. Use good quality 3.5mm jack cables (fully connected signal and ground) Unit accepts ± 4 to ± 15 V DC trigger inputs. The M8xi can then be switched on or off by remote device(s) connected to its trigger input.

Trigger output 3.5mm jack

Connect trigger input of controlling device to output socket. Use good quality 3.5mm jack cables (fully connected signal and ground). The M8xi then becomes the main controlling device and its power button will automatically switch on/off all devices connected to the trigger output.

Basic problem-solving with an amplifier is similar to troubleshooting other electrical or electronic equipment. Always check the most obvious possible causes first, such as the following examples:

Problem	Probable Cause	Remedy
No power when POWER button is pressed.	Mains power plug is not fully inserted into rear socket.	Plug in securely.
No sound	Mute function is still active. Wrong connections between input sources and the unit Outputs not connected, or incorrectly wired	Press the MUTE button on the remote control to cancel. Check audio input lead connections. Check output cables.
Sound cut	Loose connection	Check output and input connections.
Hum.	Audio connector plug not fully pushed in Cable Fault Unsuitable cable (e.g. cable grounds not connected)	Insert plug securely. Check cable is connected at both ends. N.B. Some esoteric cables have internal wiring intentionally disconnected/modified. For best results on all inputs analogue AND digital, please use good quality screened coax; signal and screens both separately connected at both ends.
No audio output, or too low level output.	Incorrect or missing connections	Check connections and make sure they are secure.
Remote control does not work.	Amplifier's POWER switch is set to off. One or more batteries fitted the wrong way around. Batteries are flat. Remote control is not pointed directly towards the front panel of the amplifier. Interference from another source.	Set switch to on. Insert batteries correctly. Change batteries for a new set. Ensure there is no obstruction between the remote control and amplifier front. Lighting such as fluorescent, incandescent, or even sunlight contains large amounts of infra red radiation. Ensure such sources are not shining directly on the infra red window as this could swamp the signal from the remote control. Also check the system and any other nearby remotes for stuck buttons.
Remote control range has greatly reduced	Batteries are running out	Change batteries for a new set.

If none of these actions affect a cure, please contact the dealer, or an authorised Musical Fidelity service agent. Remember; never open the case of the M8xi, as this will invalidate the guarantee.

Output (Balanced and single ended inputs)

Power	550W	8Ω load
Voltage	67Vrms	10Hz – 20KHz
	190V peak to peak	
Current	200A peak	
Damping factor	150	
Output devices	3+3 pairs (bridged arrangement) per channel	

	RCA single ended	XLR balanced
THD+N, 20Hz to 20 kHz	<0.005%	<0.004%
Signal / noise ratio	>80dB 'A'-weighted	>86dB 'A'-weighted
Input sensitivity for full output (vol. max)	450mV	450mV
Input impedance	25KΩ	50KΩ
Overload margin	20dB	26dB
Channel separation	>80dB	>86dB
Frequency response	+0, -1dB, 10Hz to 100 kHz	

Connections

Line inputs	2 pairs line level XLR (balanced) connectors 4 pairs line level RCA connectors
Digital inputs	1 USB B 24 bit 192kHz 2 Coaxial 24 bit 192kHz 2 Optical 24 bit 96kHz
Line outputs	1 pair line level RCA fixed 1 pair pre-out RCA variable (volume controlled) 1 pair line level XLR variable (volume controlled)
Digital outputs	1 Coaxial 1 Optical
Tigger in	1x 3.5mm mono jack accepts +/- 3 to 15V DC
Trigger Out	1x 3.5mm mono jack socket gives +12V out when unit is on

Power requirement

Mains voltages	115/230VAC 50/60Hz (factory pre-set) 100VAC 50/60Hz (alternative)
Max Consumption	2000 Watts

Weight

Unit only, unboxed	46 kg (101 lbs)
In shipping carton	48 kg (106 lbs)

Dimensions

Wide	440mm (17 ¹ / ₃ "
High, including feet	162mm (6 ³ / ₈ "
Deep (front to back) including terminals	400mm (15 ³ / ₄ "

Standard accessories

IEC C19 type mains lead 16A
M8xi remote control
Batteries, LR03 or AAA, manganese alkaline type - 2 off

Musical Fidelity reserves the right to make improvements which may result in specification or feature changes without notice.



RELEASE	DATE	CHANGES
Issue 1	05.11.2019	1 st issue

MUSICAL FIDELITY

Musical Fidelity Limited

Wirtschaftspark A5, Analogweg 1
2130 Mistelbach, Austria

www.musicalfidelity.com

Specifications and details
are correct as we go to
press, but in the interests of
product improvement they
may be subject to change
during manufacture.

August 2018