

# **Technics<sup>®</sup>**

Owner's Manual

Stereo Integrated Amplifier

**SU-C700**



Music is borderless and timeless,  
touching people's hearts across cultures and generations.  
Each day the discovery of a truly emotive experience  
from an unencountered sound awaits.  
Let us take you on your journey to rediscover music.

Rediscover Music™

**Technics**

Thank you for purchasing this product.  
Please read these instructions carefully before using this product, and save this manual for future use.

If you have any questions, visit:

U.S.A.: [www.panasonic.com/support](http://www.panasonic.com/support)

Canada: [www.panasonic.ca/english/support](http://www.panasonic.ca/english/support)

Register online at [www.panasonic.com/register](http://www.panasonic.com/register) (U.S. customers only)

## ■ Features of this unit

This unit offers the following features:

### **Full-digital amplifier with a high-precision jitter reduction circuit and PWM conversion circuit**

This unit is a full-digital amplifier. Its specially-designed jitter reduction circuit and high-precision PWM conversion circuit eliminate distortion, noise, and jitter.

### **LAPC (Load Adaptive Phase Calibration)**

Adaptive processing of speaker impedance flattens frequency amplitude and phase characteristics. The result is the reproduction of sound with rich spatial expression.

### **High-speed and lower noise linear power supply**

The combination of a large-current Schottky-barrier diode, a rectifier circuit with a large storage capacitor, and a stabilized power supply circuit achieves remarkably superior power supply that is both low-noise and plentiful.

## ■ Recommended devices

We recommend using Technics devices (optional) for superior audio quality.

Product name	Model number
Network Audio Player	ST-C700
Compact Disc Player	SL-C700*
Speaker System	SB-C700



\* This product is set to be released in July 2015.

# IMPORTANT SAFETY INSTRUCTIONS

Read these operating instructions carefully before using the unit. Follow the safety instructions on the unit and the applicable safety instructions listed below. Keep these operating instructions handy for future reference.

- 1 Read these instructions.
- 2 Keep these instructions.
- 3 Heed all warnings.
- 4 Follow all instructions.
- 5 Do not use this apparatus near water.
- 6 Clean only with dry cloth.
- 7 Do not block any ventilation openings. Install in accordance with the manufacturer's instructions.
- 8 Do not install near any heat sources such as radiators, heat registers, stoves, or other apparatus (including amplifiers) that produce heat.
- 9 Do not defeat the safety purpose of the polarized or grounding-type plug. A polarized plug has two blades with one wider than the other. A grounding-type plug has two blades and a third grounding prong. The wide blade or the third prong are provided for your safety. If the provided plug does not fit into your outlet, consult an electrician for replacement of the obsolete outlet.
- 10 Protect the power cord from being walked on or pinched particularly at plugs, convenience receptacles, and the point where they exit from the apparatus.
- 11 Only use attachments/accessories specified by the manufacturer.
- 12 Use only with the cart, stand, tripod, bracket, or table specified by the manufacturer, or sold with the apparatus. When a cart is used, use caution when moving the cart/apparatus combination to avoid injury from tip-over.
- 13 Unplug this apparatus during lightning storms or when unused for long periods of time.
- 14 Refer all servicing to qualified service personnel. Servicing is required when the apparatus has been damaged in any way, such as power-supply cord or plug is damaged, liquid has been spilled or objects have fallen into the apparatus, the apparatus has been exposed to rain or moisture, does not operate normally, or has been dropped.



	<b>CAUTION</b> RISK OF ELECTRIC SHOCK DO NOT OPEN	
<b>CAUTION :</b> TO REDUCE THE RISK OF ELECTRIC SHOCK, DO NOT REMOVE SCREWS. NO USER-SERVICEABLE PARTS INSIDE. REFER SERVICING TO QUALIFIED SERVICE PERSONNEL.		



The lightning flash with arrowhead symbol, within an equilateral triangle, is intended to alert the user to the presence of uninsulated "dangerous voltage" within the product's enclosure that may be of sufficient magnitude to constitute a risk of electric shock to persons.



The exclamation point within an equilateral triangle is intended to alert the user to the presence of important operating and maintenance (servicing) instructions in the literature accompanying the appliance.

## WARNING

### Unit

- To reduce the risk of fire, electric shock or product damage,
  - Do not expose this unit to rain, moisture, dripping or splashing.
  - Do not place objects filled with liquids, such as vases, on this unit.
  - Use only the recommended accessories.
  - Do not remove covers.
  - Do not repair this unit by yourself. Refer servicing to qualified service personnel.
  - Do not place heavy items on this unit.

### AC power supply cord

- The power plug is the disconnecting device. Install this unit so that the power plug can be unplugged from the socket outlet immediately.

## CAUTION

### Unit

- Do not place sources of naked flames, such as lighted candles, on this unit.
- Do not put any objects on this unit. This unit becomes hot while it is on.

### Placement

- To reduce the risk of fire, electric shock or product damage,
  - Do not install or place this unit in a bookcase, built-in cabinet or in another confined space. Ensure this unit is well ventilated.
  - Do not obstruct this unit's ventilation openings with newspapers, tablecloths, curtains, and similar items.
- Keep your speakers at least 10 mm (<sup>13</sup>/<sub>32</sub>" ) away from the system for proper ventilation.
- Do not lift or carry this unit by holding any of its knobs or levers. Doing so may cause this unit to fall, resulting in personal injury or malfunction of this unit.

### Battery

- Danger of explosion if battery is incorrectly replaced. Replace only with the type recommended by the manufacturer.
- Mishandling of batteries can cause electrolyte leakage and may cause a fire.
  - Remove the battery if you do not intend to use the remote control for a long period of time. Store in a cool, dark place.
  - Do not heat or expose to flame.
  - Do not leave the battery(ies) in a car exposed to direct sunlight for a long period of time with doors and windows closed.
  - Do not take apart or short circuit.
  - Do not recharge alkaline or manganese batteries.
  - Do not use batteries if the covering has been peeled off.
  - Do not mix old and new batteries or different types at the same time.
- When disposing of the batteries, please contact your local authorities or dealer and ask for the correct method of disposal.

Conforms to UL STD 60065.  
Certified to CAN/CSA STD C22.2 No.60065.

Product Identification Marking is located on the rear panel of the unit.

### THE FOLLOWING APPLIES ONLY IN THE U.S.A.

#### FCC Note:

This equipment has been tested and found to comply with the limits for a Class B digital device, pursuant to Part 15 of the FCC Rules. These limits are designed to provide reasonable protection against harmful interference in a residential installation. This equipment generates, uses and can radiate radio frequency energy and, if not installed and used in accordance with the instructions, may cause harmful interference to radio communications.

However, there is no guarantee that interference will not occur in a particular installation. If this equipment does cause harmful interference to radio or television reception, which can be determined by turning the equipment off and on, the user is encouraged to try to correct the interference by one or more of the following measures:

- Reorient or relocate the receiving antenna.
- Increase the separation between the equipment and receiver.
- Connect the equipment into an outlet on a circuit different from that to which the receiver is connected.
- Consult the dealer or an experienced radio/TV technician for help.

Any unauthorized changes or modifications to this equipment would void the user's authority to operate this device.

This device complies with Part 15 of the FCC Rules.

Operation is subject to the following two conditions:

- (1) This device may not cause harmful interference, and
- (2) this device must accept any interference received, including interference that may cause undesired operation.

Declaration of Conformity

Trade Name: Technics

Model No.: SU-C700

Responsible Party:

Panasonic Corporation of North America

Two Riverfront Plaza, Newark, NJ 07102-5490

Support Contact: <http://www.panasonic.com/contactinfo>



### THE FOLLOWING APPLIES ONLY IN CANADA

CAN ICES-3(B)/NMB-3(B)



#### Information on Disposal in other Countries outside the European Union

This symbol is only valid in the European Union. If you wish to discard this product, please contact your local authorities or dealer and ask for the correct method of disposal.

# Table of contents

IMPORTANT SAFETY INSTRUCTIONS.....	5	Listening to audio from a PC, etc.....	15
Accessories.....	6	Troubleshooting.....	16
Unit care .....	6	Specifications.....	17
Control reference guide .....	7	Limited Warranty (ONLY FOR U.S.A.).....	18
Getting started .....	9	Limited Warranty (ONLY FOR CANADA).....	19
Operations.....	13		

## About descriptions in this Owner's Manual

- Pages to be referred to are indicated as "⇒ ○○".
- The illustrations shown may differ from your unit.
- Unless otherwise indicated, operations are described using the remote control.

## Accessories

- 1 AC power supply cord  
(K2CB2YY00098)

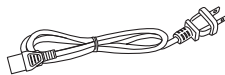

- 1 Remote control  
(N2QAYA000096)



- 2 Batteries for remote control



(ONLY FOR CANADA)

The enclosed Canadian French label sheet corresponds to the English display on the unit.



- Product numbers provided in this Owner's Manual are correct as of December 2014. These may be subject to change.
- Do not use AC power supply cord with other equipment.

## ■ Using the remote control

Insert the battery so the terminals (+ and -) match those in the remote control.  
Point it at the remote control signal sensor on this unit. (⇒ 7)

- Keep the batteries out of reach of children to prevent swallowing.

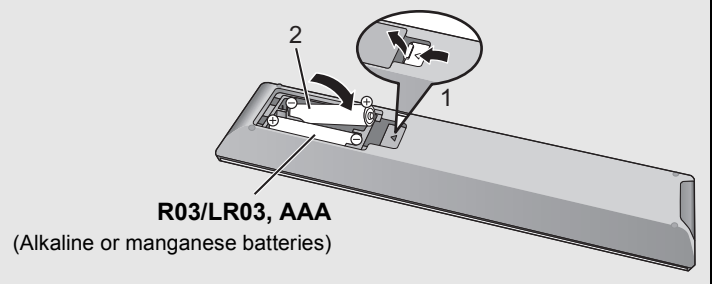

## Unit care

Pull out the AC power supply cord from the outlet before maintenance. Clean this unit with a soft cloth.

- When dirt is heavy, wring a wet cloth tightly to wipe the dirt, and then wipe it with a soft cloth.
- Do not use solvents including benzine, thinner, alcohol, kitchen detergent, a chemical wiper, etc. This might cause the exterior case to be deformed or the coating to come off.

# Control reference guide

## This unit

### ■ Front

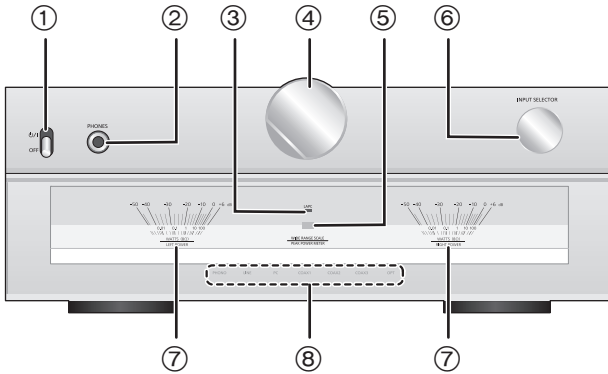

- ① **Power switch lever**  
Turn on/off this unit.
  - The remote control do not operate when the power switch lever is in the lowered position.
- ② **Headphones jack**  
For connecting a headphone plug.
  - When a plug is connected, the speakers do not output sound.
  - Excessive sound pressure from earphones and headphones can cause hearing loss.
  - Listening at full volume for long periods may damage the user's ears.
- ③ **LAPC indicator (⇒ 13)**  
The indicator lights up when amplifier output correction is on.
- ④ **Volume knob**  
Adjust the volume.
  - When this unit is muted, if you turn the knob anticlockwise until it stops and then turn it clockwise, the muting will be canceled.
- ⑤ **Remote control signal sensor**  
Distance: Within approx. 7 m (23 ft) directly in front  
Angle: Approx. 30° left and right
- ⑥ **Input selector knob**  
Turn this knob clockwise or anticlockwise to switch the input source. (⇒ 13)
- ⑦ **Peak power meter**  
Display the output level.
- ⑧ **Input indicator (⇒ 13)**  
The indicator for the selected input source lights up.
  - The indicator blinks if you select "PC", "COAX1", "COAX2", "COAX3" or "OPT" when the device is not connected to this unit.

### ■ Rear

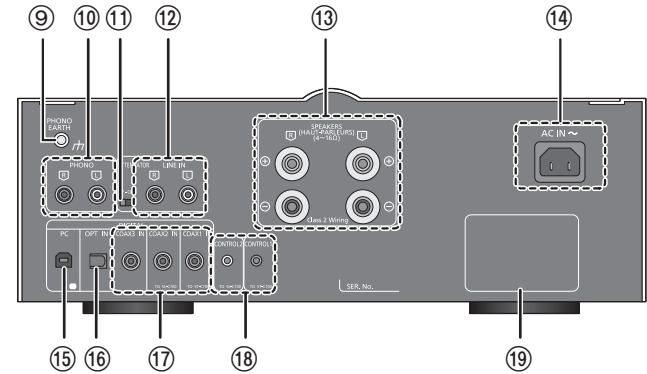

- ⑨ **PHONO EARTH terminal [PHONO EARTH] (⇒ 11)**  
For connecting the ground wire of a record player.
- ⑩ **Analog audio input terminal [PHONO] (⇒ 11)**  
For connecting a record player.
  - MM cartridges are supported.
- ⑪ **Attenuator [ATTENUATOR]**  
If audio distortion occurs when using the analog audio input terminal [LINE IN], set this switch to [ON].
- ⑫ **Analog audio input terminal [LINE IN] (⇒ 11)**
- ⑬ **Speaker terminals [SPEAKERS] (⇒ 9)**
- ⑭ **AC IN terminal [AC IN ~] (⇒ 12)**
- ⑮ **Digital audio input terminal [PC] (⇒ 15)**  
For connecting to a PC, etc.
- ⑯ **Digital audio input terminal [OPT IN] (⇒ 11)**
- ⑰ **Digital audio input terminals [COAX1 IN]/[COAX2 IN]/[COAX3 IN] (⇒ 10, 11)**
- ⑱ **System terminals [CONTROL1]/[CONTROL2] (⇒ 10)**
- ⑲ **Product identification marking**  
The model number is indicated.

# Remote control

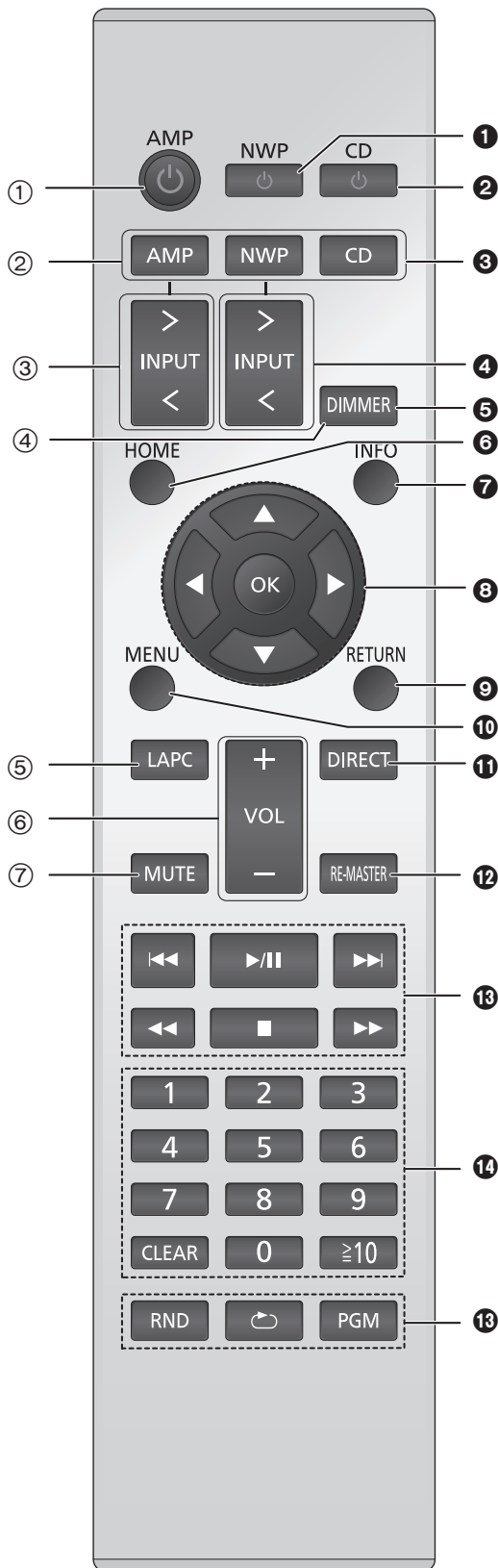

## ■ Buttons that work for this unit

- ① **[AMP   - The remote control do not operate when the power switch lever is in the lowered position.**
- ② **[AMP]/[NWP]/[CD]: Select the device to be operated**

[AMP]	LINE indicator lights up
[NWP]	COAX1 indicator lights up
[CD]	COAX2 indicator lights up
- ③ **[> INPUT <]: Select the input source (⇒ 13)**
- ④ **[DIMMER]: Adjust the brightness of the light and the indicators**  
Each press of this button switches the brightness.
- ⑤ **[LAPC]: Measure the characteristics of the amplifier and correct its output (⇒ 13)**
- ⑥ **[+ VOL -]: Adjust the volume**
- ⑦ **[MUTE]: Mute the sound**  
Input indicator blinks. Press [MUTE] again to cancel.

## ■ Buttons that work for the ST-C700/SL-C700

The remote control of this unit also works for the ST-C700/SL-C700.  
For information on the operations of the ST-C700/SL-C700, please also refer to their operating instructions.

- ❶ Standby/on switch for the ST-C700
- ❷ Standby/on switch for the SL-C700
- ❸ Select the device to be operated
- ❹ Select the input source of the ST-C700
- ❺ Adjust the display brightness
- ❻ Display HOME menu
- ❼ Change the displayed information
- ❽ Selection/OK
- ❾ Return to the previous display
- ❿ Enter menu
- ⓫ Turn on/off Direct mode
- ⓬ Turn on/off Re-master
- ⓭ Basic playback control buttons
- ⓮ Numeric buttons, etc.



# Getting started

- Turn off all equipment before connection and read the appropriate operating instructions.
- Do not connect the AC power supply cord until all other connections are complete.
- Insert the plugs of the cables to be connected all the way in.
- Do not bend cables at sharp angles.

## Speaker connection

e.g.,

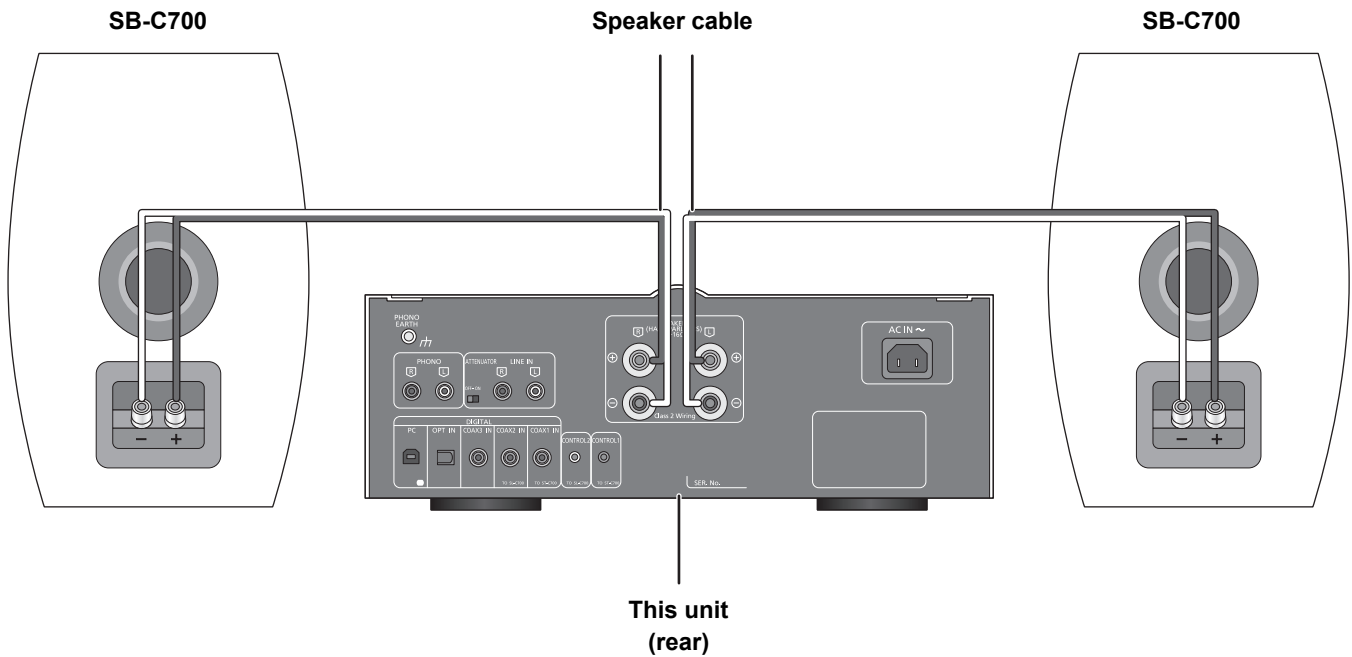

**1** Turn the knobs to loosen them, and insert the core wires into the holes.

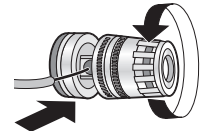

**2** Tighten the knobs.



- When the connections are completed, pull the speaker cables lightly to check that they are connected firmly.
- Be careful not to cross (short-circuit) or reverse the polarity of the speaker wires as doing so may damage the amplifier.
- Wire the polarity (+/-) of the terminals correctly. Not doing so may adversely affect stereo effects or cause malfunction.
- For details, refer to the operating instructions of the speakers.

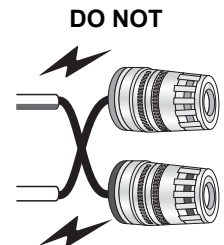

## System control connection to an ST-C700/SL-C700

- You can input digital audio signals to this unit and play back music.
- You can automatically link this unit with the ST-C700/SL-C700 and operate them easily with the remote control. (⇒ 14)

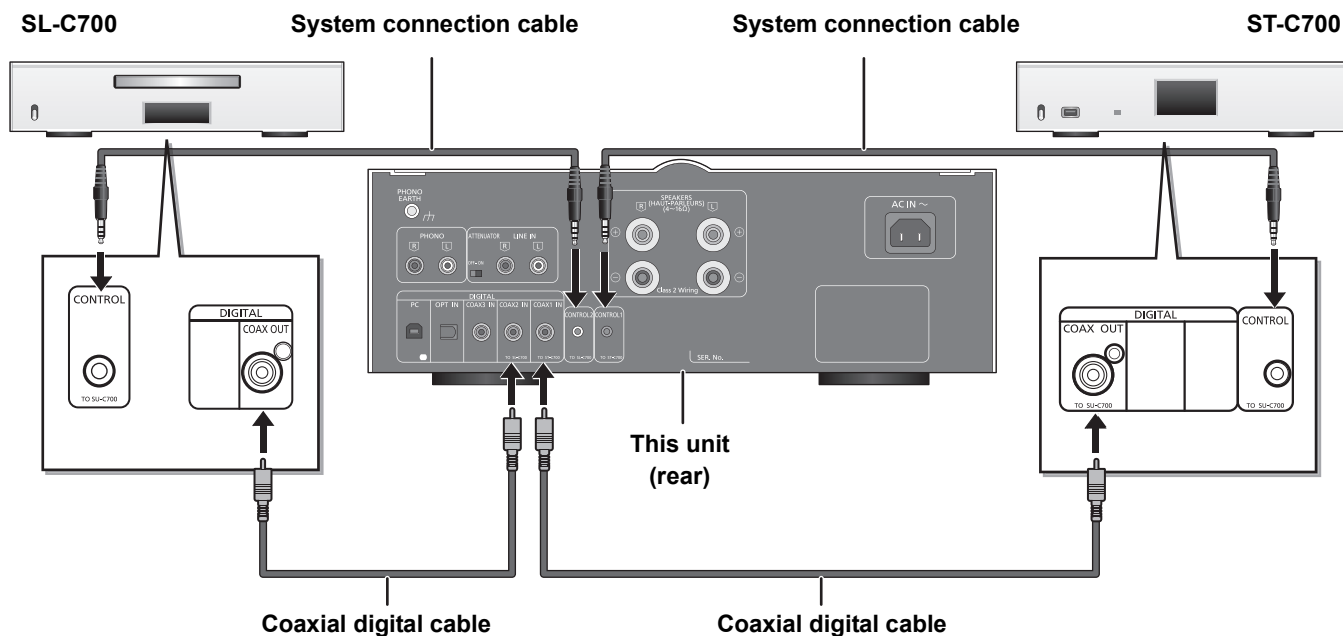

- Use the system connection cables and the coaxial digital cables supplied with the ST-C700/SL-C700.
- Connect the system connection cables to the system terminals [CONTROL1]/[CONTROL2]. Connect the ST-C700 to [CONTROL1] and the SL-C700 to [CONTROL2].
- Connect coaxial digital cables to the digital audio input terminals [COAX1 IN]/[COAX2 IN]. Connect the ST-C700 to [COAX1 IN] and the SL-C700 to [COAX2 IN].

## Connecting to analog audio output devices

You can input analog audio signals to this unit and play back music.

e.g.,

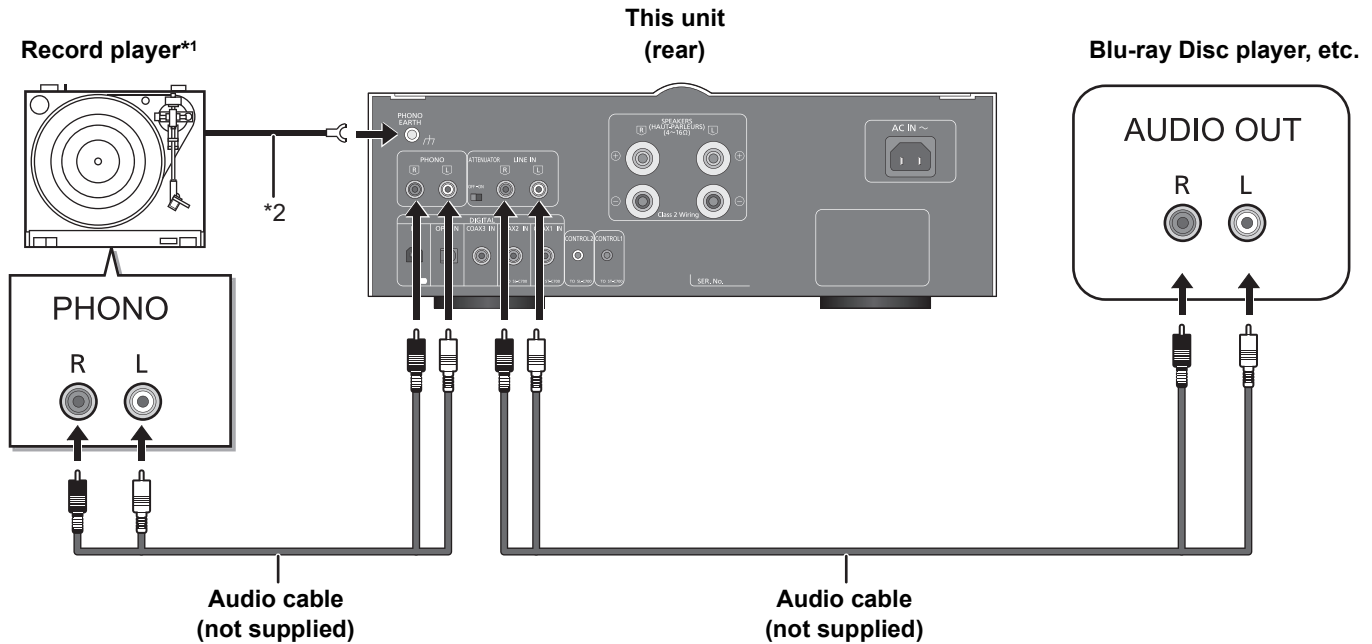

\*1 When connecting to a record player with a built-in PHONO equalizer, connect its cable to the analog audio input terminal [LINE IN].

\*2 When connecting a record player with a ground wire, connect the ground wire to the PHONO EARTH terminal [PHONO EARTH] of this unit.

## Connecting to digital audio output devices

You can input digital audio signals to this unit and play back music.

e.g.,

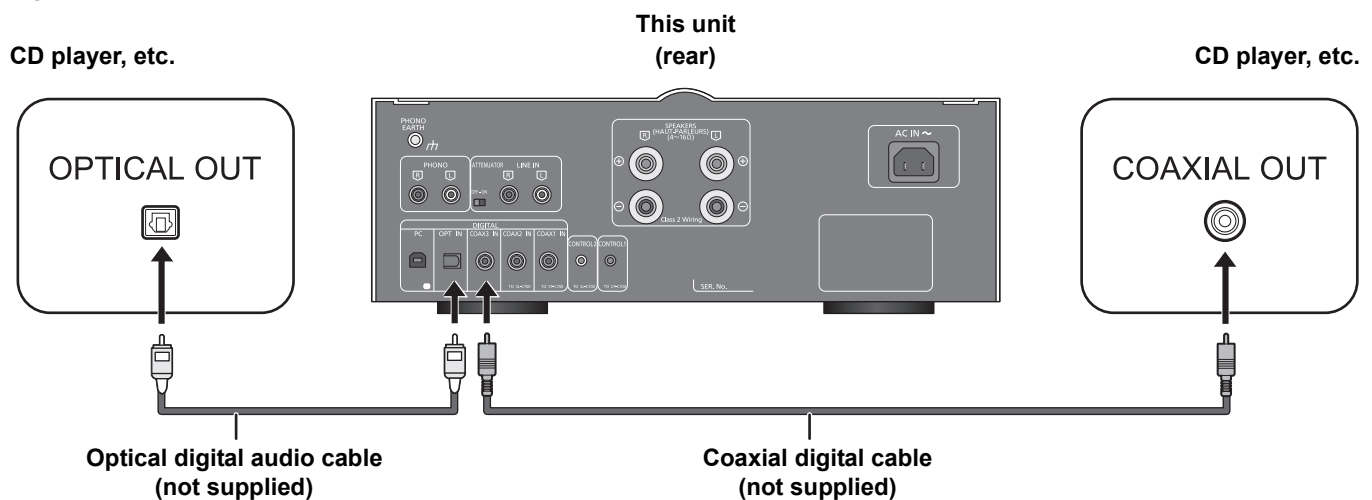

• The digital audio input of this unit supports only the linear PCM (LPCM) signals listed below. For details, refer to the operating instructions of the connected device.

Input terminal	Sampling frequency	Number of quantization bits
Coaxial digital input	32/44.1/48/88.2/96/176.4/192 kHz	16/24 bit
Optical digital input	32/44.1/48/88.2/96 kHz	16/24 bit

## AC power supply cord connection

Connect only after all other connections are completed.

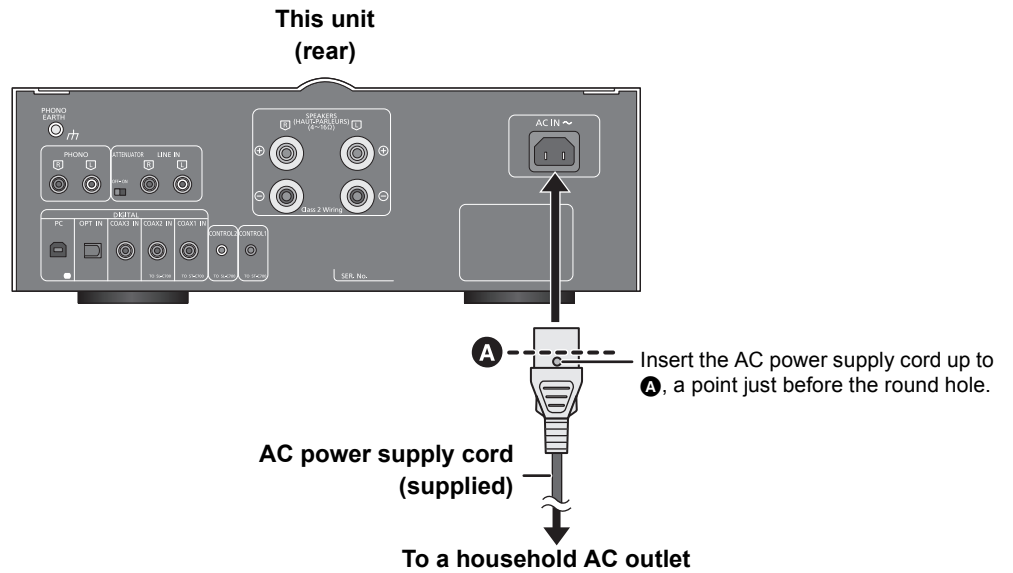

- This unit consumes a small amount of AC power (⇒ 17) even the power switch lever is in the [OFF] position. Remove the plug from the main electrical outlet if you will not be using the unit for an extended period of time. Place the unit so the plug can be easily removed.

# Operations

## Measuring the characteristics of the amplifier and correcting its output

To optimize the audio output, you can measure the amplifier characteristics and correct its output when it is connected to the speakers.

- Disconnect the headphones. If you connect them during amplifier characteristic measurement or amplifier output correction, it will be canceled.

### Test tone emitted during measurement

To ensure the measurement accuracy, the speakers output a test tone at regular intervals. (For approximately 4 minutes)

It is not possible to change the volume of the audio being output while the measurement is in progress.

- 1 Raise the power switch lever of this unit to the [⏻/⏪] position.
- 2 Press and hold [LAPC] until the LAPC indicator on this unit starts to blink.
  - This unit will start measuring the characteristics of the amplifier. Check that a test tone is output from both the left and right speakers.
    - If you press [LAPC] while the measurement is in progress, it will be canceled. The LAPC indicator on this unit will go off.
  - When the measurement is complete, amplifier output correction will be automatically turned on. The LAPC indicator on this unit will light up.

## ■ Turning on/off the output correction function

### Press [LAPC].

Each time you press the button:

LAPC indicator lights up	On
LAPC indicator goes off	Off



- Depending on the type of the connected speakers, the effect of the output correction function may be minimal.
- The corrected output remains in effect until you measure the characteristics again. When you use other speakers, redo the measurement.

- Reduce the volume to minimum.

- 1 Raise the power switch lever of this unit to the [⏻/⏪] position.
- 2 Press [➤ INPUT <] below [AMP] to select the input source.

The indicator of the selected input source will light up.

PHONO	Analog audio input (PHONO)
LINE	Analog audio input (LINE IN)
PC	Digital audio input (PC) (⇒ 15)
COAX1	• Digital audio input (COAX1 IN) • ST-C700
COAX2	• Digital audio input (COAX2 IN) • SL-C700
COAX3	Digital audio input (COAX3 IN)
OPT	Digital audio input (OPT IN)

- 3 Operate the device to be used for playback.
- 4 Press [+ VOL -] to adjust the volume.

## Auto off function

This unit is designed to conserve its power consumption and save energy. The unit will turn to standby mode automatically if there is no sound and it is not being used for approximately 20 minutes.

- The factory default is "On".

### To cancel this function

**1** Press and hold [MUTE] until the PHONO indicator on this unit starts to blink.

**2** Press [MUTE].

Each time you press the button:

COAX3 indicator blinks	On
OPT indicator blinks	Off

**3** Press [VOL -] to exit.



- You will exit the auto off setup mode if you do not operate any buttons and controls for approximately 10 seconds after any of the three indicators above starts blinking.

## Remote control code

When other equipment responds to the supplied remote control, change the remote control code.

- The factory default is "1".

**Point the remote control at this unit, and press and hold [OK] and the numeric button for at least 4 seconds.**

- When the code is changed, the PC indicator and the COAX2 indicator blink for approximately 10 seconds.

[OK] + [1]	Set the code to 1
[OK] + [2]	Set the code to 2



- When the ST-C700/SL-C700 is connected via the system control function, change its remote control code as well as the remote control code for this unit.

## Using the system control function

You can automatically link this unit with the ST-C700/SL-C700 and operate them easily with the remote control.

### Preparation

- ① Connect this unit and the ST-C700/SL-C700 with system connection cables and coaxial digital cables. (⇒ 10)
- ② Set the power switch lever of this unit and the ST-C700/SL-C700 to the [⏻/|] position.

### ■ Switching this unit and the ST-C700/SL-C700 to on/standby simultaneously

- If you point the remote control at this unit and press [AMP ⏻] when this unit and the ST-C700/SL-C700 are in standby mode, this unit and the device of the selected input source will be turned on simultaneously.
- If you point the remote control at this unit and press [AMP ⏻] when this unit and the ST-C700/SL-C700 are turned on, this unit and the ST-C700/SL-C700 will simultaneously enter standby mode.

### ■ Switching this unit's input source automatically

When you perform an operation such as playback on the ST-C700/SL-C700, the input source of this unit will be automatically switched to "COAX1"/"COAX2".



- For information on the operations of the ST-C700/SL-C700, please also refer to their operating instructions.
- If you install the dedicated app "Technics Music App" (free of charge) on your tablet/smartphone, you can use a wide variety of functions when the unit and the ST-C700 are connected. For details, visit:  
[www.technics.com/support/](http://www.technics.com/support/)

# Listening to audio from a PC, etc.

You can connect the digital audio input terminal [PC] and a PC, etc. with a USB cable and play back music on the PC, etc. with this unit.

## Connecting to a PC

Before connecting to a PC, follow the steps below.

• Refer to the following for the recommend OS versions for your PC:

- Windows Vista, Windows 7, Windows 8, Windows 8.1
- OS X 10.7, 10.8, 10.9, 10.10

① Download and install the dedicated driver to the PC. (Only for Windows OS)

Download and install the driver from the website below.

[www.technics.com/support/](http://www.technics.com/support/)

② Download and install the dedicated app “Technics Audio Player” (free of charge) on your PC. (Common to both Windows OS and OS X)

Download and install the app from the website below.

[www.technics.com/support/](http://www.technics.com/support/)

(as of November 2014)

**1** Disconnect the AC power supply cord.

**2** Connect this unit and a PC, etc.

e.g.,

PC, etc.

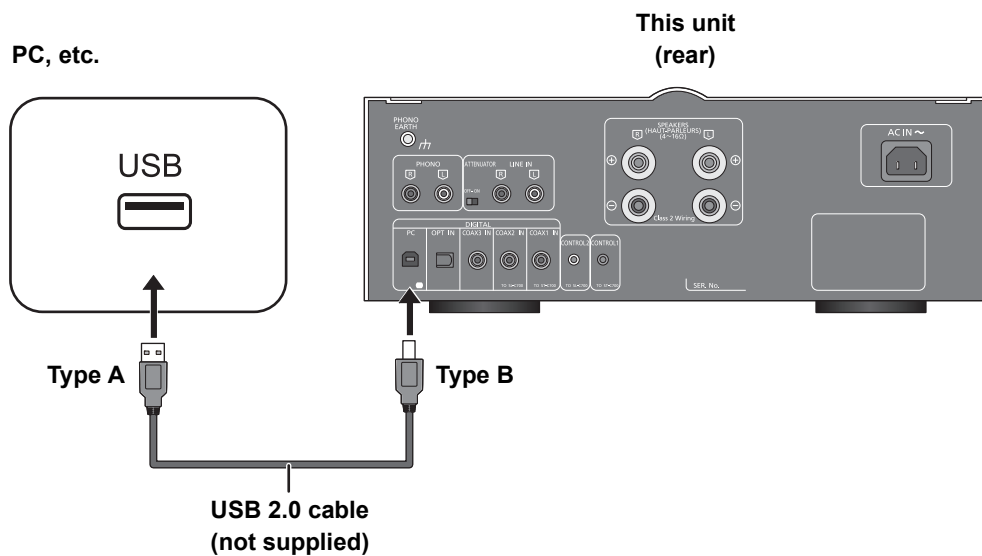

**3** Connect the AC power supply cord to this unit, and raise the power switch lever to the [⏻/⏻] position. (⇒ 12)

**4** Press [➤ INPUT <] below [AMP] repeatedly to select “PC”.

**5** Operate the PC, etc. for playback.

**6** Press [+ VOL –] to adjust the volume.

• OS X is a trademark of Apple Inc., registered in the U.S. and other countries.

• Windows and Windows Vista are either registered trademarks or trademarks of Microsoft Corporation in the United States and/or other countries.

# Troubleshooting





Before requesting service, make the following checks. If you are uncertain about some of the check points, or if the solutions indicated in the following guide does not resolve the issue, then consult your dealer for instructions.

## To return all settings to the factory defaults

When the following situations occur, reset the memory:

- There is no response when buttons are pressed.
- You want to clear and reset the memory contents.

### When the unit is off:

- ① Press and hold [AMP .
- ② While continuing to hold [AMP , raise the power switch lever of this unit to the [/I] position.
  - Keep holding [AMP ] until the PC indicator and the COAX2 indicator blink twice.

## Heat buildup of this unit.

- This unit becomes warm when the volume is high. This is not a malfunction.

## A “humming” sound can be heard during playback.

- An AC power supply cord or fluorescent light is near the cables. Keep other appliances and cords away from the cables of this unit.
- Set the [ATTENUATOR] switch to [ON]. (⇒ 7)
- A strong magnetic field near a TV or other device may adversely affect the audio quality. Keep this unit away from such devices.
- The speakers may output noise when a device nearby is emitting powerful radio waves, such as when a mobile phone is on a call.

## No sound.

- Check connections to speakers and other equipment. After checking the connections, measure the characteristics of the amplifier. (⇒ 13)
- Check to see if the correct input source is selected.
- Insert the plugs of the cables to be connected all the way in.
- Playback of multi-channel content is not supported.
- The digital audio input terminals of this unit can only detect linear PCM (LPCM) signals. For details, refer to the operating instructions of the connected device.

## The remote control does not work properly.

- To avoid interference, please do not put any objects in front of signal sensor. (⇒ 7)
- Change the remote control code if other products react to this remote control. (⇒ 14)

## Pressing [DIMMER] changes the display and the basic control switches brightness of the ST-C700/SL-C700.

- [DIMMER] works for the ST-C700/SL-C700 as well as this unit. Turn off the device that you want to maintain the brightness level of, and press [DIMMER].

## The peak power meter does not operate.

- In the following cases, this meter does not operate:
  - When a headphone plug is connected.
  - When the peak power meter light is turned off by pressing [DIMMER].
  - When this unit is muted by pressing [MUTE].

## The system control function is not working.

- Use the system connection cables supplied with the ST-C700/SL-C700.
- Connect the system connection cables to the system terminals [CONTROL1]/[CONTROL2]. Connect the ST-C700 to [CONTROL1] and the SL-C700 to [CONTROL2].
- Connect coaxial digital cables to the digital audio input terminals [COAX1 IN]/[COAX2 IN]. Connect the ST-C700 to [COAX1 IN] and the SL-C700 to [COAX2 IN].

## The unit turns off automatically.

- Is the auto off function turned on? (⇒ 14)
- If the ST-C700 is connected to this unit via the system control function, this unit may automatically enter standby mode when the ST-C700 enters standby mode. (⇒ 10, 14)
- This unit incorporates a protection circuit to prevent damage caused by heat buildup. When you use this unit at a high volume level for a long period of time, it may turn off automatically. Wait for this unit to cool down before turning on this unit again. (For approximately 3 minutes)

## Input indicator blinks.

- In the following cases, the input indicator blinks:
  - When this unit is muted by pressing [MUTE].
  - “PC”, “COAX1”, “COAX2”, “COAX3” or “OPT” is selected, but no device is connected.
  - Audio signals, such as sampling frequency components, are not input correctly.



# Specifications

## ■ GENERAL

Power supply	AC 120 V, 60 Hz
Power consumption	73 W
Power consumption in standby mode	Approx. 0.3 W
Power consumption in off mode	Approx. 0.3 W
Dimensions (W×H×D)	340 mm×132 mm×325 mm (13 3/8"×5 7/32"×12 13/16")
Mass (Weight)	Approx. 8.3 kg (18.3 lbs)
Operating temperature range	0 °C to +40 °C (+32 °F to +104 °F)
Operating humidity range	35 % to 80 % RH (no condensation)

## ■ AMPLIFIER SECTION

FTC output power	45 W + 45 W (20 Hz to 20 kHz, T.H.D. 0.5 %, 8 Ω, 20 kHz LPF) 70 W + 70 W (20 Hz to 20 kHz, T.H.D. 0.5 %, 4 Ω, 20 kHz LPF)
Load impedance	4 Ω to 16 Ω
Frequency response	
PHONO (MM)	20 Hz to 20 kHz (RIAA DEVIATION ±1 dB, 8 Ω)
LINE	20 Hz to 80 kHz (−3 dB, 8 Ω)
COAX1/2/3	20 Hz to 90 kHz (−3 dB, 8 Ω)
Input sensitivity/Input impedance	
LINE	200 mV / 22 kΩ
PHONO (MM)	2.5 mV / 47 kΩ

## ■ TERMINALS SECTION

Headphones jack	Stereo, Ø6.3 mm (1/4")
USB port	
USB Standard	USB 2.0 high-speed
USB Audio Class specification	USB Audio Class 2.0, Asynchronous mode
Connector	USB Standard B connector
Format support	LPCM (32/44.1/48/88.2/96/176.4/192 kHz, 16/24/32 bit) DSD (2.8224 MHz, 5.6448 MHz)
DSD control mode	ASIO Native mode, DoP mode DSD64/DSD128 playback
Channel	2 ch
Analog input	
Line input	Pin jack
PHONO (MM)	Pin jack
Digital input	
Optical digital input	Optical terminal
Coaxial digital input ×3	Pin jack
Format support	LPCM
System port	
System control ×2	Ø3.5 mm (1/8") jack



- Specifications are subject to change without notice.
- Mass and dimensions are approximate.

---

• "Direct Stream Digital", DSD and their logos are trademarks of Sony Corporation.



# Limited Warranty (ONLY FOR CANADA)

## Panasonic Canada Inc.

5770 Ambler Drive, Mississauga, Ontario L4W 2T3

### TECHNICS PRODUCT – LIMITED WARRANTY

Panasonic Canada Inc. warrants this product to be free from defects in material and workmanship under normal use and for a period as stated below from the date of original purchase agrees to, at its option either (a) repair your product with new or refurbished parts, (b) replace it with a new or a refurbished equivalent value product, or (c) refund your purchase price. The decision to repair, replace or refund will be made by Panasonic Canada Inc.

<b>Technics Stereo Integrated Amp</b>	<b>3 (three) years parts and labour</b>
<b>Technics Network Audio Player</b>	<b>3 (three) years parts and labour</b>
<b>Technics Speaker System</b>	<b>3 (three) years parts and labour</b>
<b>Technics Compact Disc Player</b>	<b>2 (two) years parts and labour</b>

This warranty is given only to the original purchaser, or the person for whom it was purchased as a gift, of a Technics brand product mentioned above sold by an authorized Panasonic dealer in Canada and purchased and used in Canada, which product was not sold "as is", and which product was delivered to you in new condition in the original packaging.

**IN ORDER TO BE ELIGIBLE TO RECEIVE WARRANTY SERVICE HEREUNDER, A PURCHASE RECEIPT OR OTHER PROOF OF DATE OF ORIGINAL PURCHASE, SHOWING AMOUNT PAID AND PLACE OF PURCHASE IS REQUIRED**

#### **LIMITATIONS AND EXCLUSIONS**

This warranty ONLY COVERS failures due to defects in materials or workmanship, and DOES NOT COVER normal wear and tear or cosmetic damage. The warranty ALSO DOES NOT COVER damages which occurred in shipment, or failures which are caused by products not supplied by Panasonic Canada Inc., or failures which result from accidents, misuse, abuse, neglect, mishandling, misapplication, alteration, faulty installation, set-up adjustments, misadjustment of consumer controls, improper maintenance, power line surge, lightning damage, modification, introduction of sand, humidity or liquids, commercial use such as hotel, office, restaurant, or other business or rental use of the product, or service by anyone other than an Authorized Servicer, or damage that is attributable to acts of God.

Dry cell batteries are also excluded from coverage under this warranty.

THIS EXPRESS, LIMITED WARRANTY IS IN LIEU OF ALL OTHER WARRANTIES, EXPRESS OR IMPLIED, INCLUDING ANY IMPLIED WARRANTIES OF MERCHANTABILITY AND FITNESS FOR A PARTICULAR PURPOSE. IN NO EVENT WILL PANASONIC CANADA INC. BE LIABLE FOR ANY SPECIAL, INDIRECT OR CONSEQUENTIAL DAMAGES RESULTING FROM THE USE OF THIS PRODUCT OR ARISING OUT OF ANY BREACH OF ANY EXPRESS OR IMPLIED WARRANTY. (As examples, this warranty excludes damages for lost time, travel to and from the Authorized Servicer, loss of or damage to media or images, data or other memory or recorded content. This list of items is not exhaustive, but for illustration only.)

In certain instances, some jurisdictions do not allow the exclusion or limitation of incidental or consequential damages, or the exclusion of implied warranties, so the above limitations and exclusions may not be applicable. This warranty gives you specific legal rights and you may have other rights which vary depending on your province or territory.

#### **WARRANTY SERVICE**

For product operation, repairs and information assistance, please visit our Support page on:

**[www.panasonic.ca/english/support](http://www.panasonic.ca/english/support)**

#### **IF YOU SHIP THE PRODUCT TO A SERVICENTRE**

Carefully pack and send prepaid, adequately insured and preferably in the original carton.  
Include details of the defect claimed, and proof of date of original purchase.

---

**Panasonic Corporation of North America**

Two Riverfront Plaza, Newark, NJ 07102-5490

***<http://www.panasonic.com>***

**Panasonic Canada Inc.**

5770 Ambler Drive,  
Mississauga, Ontario,  
L4W 2T3

***[www.panasonic.com](http://www.panasonic.com)***

Ⓔ