

TEAC

CR-H101

CD Receiver



REFERENCE MANUAL

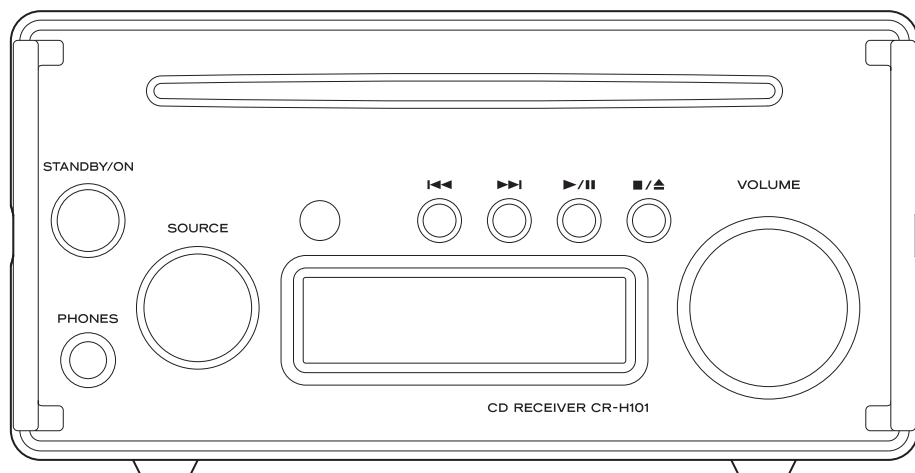

IMPORTANT SAFETY INSTRUCTIONS



CAUTION
RISK OF ELECTRIC SHOCK
DO NOT OPEN



CAUTION: TO REDUCE THE RISK OF ELECTRIC SHOCK, DO NOT REMOVE COVER (OR BACK). NO USER-SERVICEABLE PARTS INSIDE. REFER SERVICING TO QUALIFIED SERVICE PERSONNEL.



The lightning flash with arrowhead symbol, within an equilateral triangle, is intended to alert the user to the presence of un-insulated "dangerous voltage" within the product's enclosure that may be of sufficient magnitude to constitute a risk of electric shock to persons.



The exclamation point within an equilateral triangle is intended to alert the user to the presence of important operating and maintenance (servicing) instructions in the literature accompanying the appliance.

WARNING: TO PREVENT FIRE OR SHOCK HAZARD, DO NOT EXPOSE THIS APPLIANCE TO RAIN OR MOISTURE.

CLASS II apparatus with double insulation, and no protective earth provided.



CAUTION

- DO NOT REMOVE THE EXTERNAL CASES OR CABINETS TO EXPOSE THE ELECTRONICS. NO USER SERVICEABLE PARTS ARE INSIDE.
- IF YOU ARE EXPERIENCING PROBLEMS WITH THIS PRODUCT, CONTACT THE STORE WHERE YOU PURCHASED THE UNIT FOR A SERVICE REFERRAL. DO NOT USE THE PRODUCT UNTIL IT HAS BEEN REPAIRED.
- USE OF CONTROLS OR ADJUSTMENTS OR PERFORMANCE OF PROCEDURES OTHER THAN THOSE SPECIFIED HEREIN MAY RESULT IN HAZARDOUS RADIATION EXPOSURE.

IN USA/CANADA, USE ONLY ON 120 V SUPPLY.

The nameplate is located on the bottom of the unit as shown below.

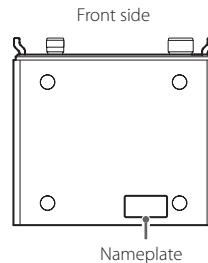

The Bluetooth® word mark and logos are registered trademarks owned by Bluetooth SIG, Inc. and any use of such marks by TEAC CORPORATION is under license.

© 2013 CSR plc and its group companies. The aptX® mark and the aptX logo are trade marks of CSR plc or one of its group companies and may be registered in one or more jurisdictions.

This product is protected by certain intellectual property rights of Microsoft. Use or distribution of such technology outside of this product is prohibited without a license from Microsoft.

Windows is a registered trademark of Microsoft Corporation in the United States and/or other countries.

Mac, Mac OS and OS X are trademarks of Apple Inc., registered in the U.S. and other countries.

Other company names, product names and logos in this document are the trademarks or registered trademarks of their respective owners.

- 1) Read these instructions.
- 2) Keep these instructions.
- 3) Heed all warnings.
- 4) Follow all instructions.
- 5) Do not use this apparatus near water.
- 6) Clean only with dry cloth.
- 7) Do not block any ventilation openings. Install in accordance with the manufacturer's instructions.
- 8) Do not install near any heat sources such as radiators, heat registers, stoves, or other apparatus (including amplifiers) that produce heat.
- 9) Do not defeat the safety purpose of the polarized or grounding-type plug. A polarized plug has two blades with one wider than the other. A grounding type plug has two blades and a third grounding prong. The wide blade or the third prong are provided for your safety. If the provided plug does not fit into your outlet, consult an electrician for replacement of the obsolete outlet.
- 10) Protect the power cord from being walked on or pinched particularly at plugs, convenience receptacles, and the point where they exit from the apparatus.
- 11) Only use attachments/accessories specified by the manufacturer.
- 12) Use only with the cart, stand, tripod, bracket, or table specified by the manufacturer, or sold with the apparatus. When a cart is used, use caution when moving the cart/apparatus combination to avoid injury from tip-over.
- 13) Unplug this apparatus during lightning storms or when unused for long periods of time.
- 14) Refer all servicing to qualified service personnel. Servicing is required when the apparatus has been damaged in any way, such as power-supply cord or plug is damaged, liquid has been spilled or objects have fallen into the apparatus, the apparatus has been exposed to rain or moisture, does not operate normally, or has been dropped.
 - The apparatus draws nominal non-operating power from the AC outlet with its POWER or STANDBY/ON switch not in the ON position.
 - The mains plug is used as the disconnect device, the disconnect device shall remain readily operable.
 - Caution should be taken when using earphones or headphones with the product because excessive sound pressure (volume) from earphones or headphones can cause hearing loss.



CAUTION

- Do not expose this apparatus to drips or splashes.
- Do not place any objects filled with liquids, such as vases, on the apparatus.
- Do not install this apparatus in a confined space such as a book case or similar unit.
- The apparatus should be located close enough to the AC outlet so that you can easily reach the power cord plug at any time.
- If the product uses batteries (including a battery pack or installed batteries), they should not be exposed to sunshine, fire or excessive heat.
- CAUTION for products that use replaceable lithium batteries: there is danger of explosion if a battery is replaced with an incorrect type of battery. Replace only with the same or equivalent type.

⚠ Precautions concerning batteries

Misuse of batteries could cause them to rupture or leak leading to fire, injury or the staining of nearby things. Please read and observe the following precautions carefully.

- Be sure to insert the batteries with correct positive (+) and negative (−) orientations.
- Use batteries of the same type. Never use different types of batteries together.
- If the remote control is not used for a long time (more than a month), remove the batteries to prevent them from leaking.
- If the batteries leak, wipe away the leakage inside the battery compartment and replace the batteries with new ones.
- Do not use batteries of types other than those specified. Do not mix new batteries with old ones or use different types of batteries together.
- Do not heat or disassemble batteries. Never throw batteries into fire or water.
- Do not carry or store batteries with other metallic objects. The batteries could short circuit, leak or explode.
- Never recharge a battery unless it is confirmed to be a rechargeable type.

IMPORTANT SAFETY INSTRUCTIONS (continued)

Laser information

This product contains a semiconductor laser system inside the cabinet and is classified as a "CLASS 1 LASER PRODUCT". To prevent being exposed to the laser beam, do not try to open the enclosure.

Laser:

Type: EP-HD870PB

Manufacturer: GUANGDONG EVER BRIGHT GROUP CO.,LTD

Laser output: Less than 1 mW on the objective lens

Wavelength: 792±25 nm

Model for USA

This product has been designed and manufactured according to FDA regulations "title 21, CFR, chapter 1, subchapter J, based on the Radiation Control for Health and Safety Act of 1968", and is classified as class I laser product. There is not hazardous invisible laser radiation during operation because invisible laser radiation emitted inside of this product is completely confined in the protective housings.

The label required in this regulation is as follows:

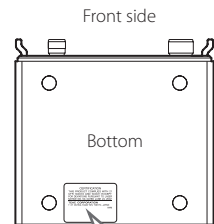



CERTIFICATION
THIS PRODUCT COMPLIES WITH 21
CFR 1040.10 AND 1040.11 EXCEPT
FOR DEVIATIONS PURSUANT TO LASER
NOTICE NO. 50, DATED JUNE 24, 2007.

TEAC CORPORATION
1-47 OCHIAI, TAMA-SHI, TOKYO, JAPAN

For European Customers

Disposal of electrical and electronic equipment and batteries and/or accumulators

- All electrical/electronic equipment and waste batteries/accumulators should be disposed of separately from the municipal waste stream via collection facilities designated by the government or local authorities.
- By disposing of electrical/electronic equipment and waste batteries/accumulators correctly, you will help save valuable resources and prevent any potential negative effects on human health and the environment.
- Improper disposal of waste electrical/electronic equipment and batteries/accumulators can have serious effects on the environment and human health because of the presence of hazardous substances in the equipment.
- The Waste Electrical and Electronic Equipment (WEEE) symbols, which show wheeled bins that have been crossed out, indicate that electrical/electronic equipment and batteries/accumulators must be collected and disposed of separately from household waste.

If a battery or accumulator contains more than the specified values of lead (Pb), mercury (Hg), and/or cadmium (Cd) as defined in the Battery Directive (2006/66/EC), then the chemical symbols for those elements will be indicated beneath the WEEE symbol.

Pb, Hg, Cd
- Return and collection systems are available to end users. For more detailed information about the disposal of old electrical/electronic equipment and waste batteries/accumulators, please contact your city office, waste disposal service or the shop where you purchased the equipment.

DECLARATION OF CONFORMITY

We, TEAC AUDIO EUROPE, Gutenbergstr. 3, 82178 Puchheim, Germany declare in own responsibility, the TEAC product described in this manual is in compliance with the corresponding technical standards.



Wireless equipment precautions

Compliance of radio transmitter and interference

Model for USA

Declaration of Conformity

Responsible party:
TEAC AMERICA, INC.

Address: 1834 Gage Road, Montebello,
California, U.S.A.

Telephone number : 1-323-726-0303

This device complies with Part 15 of the FCC Rules. Operation is subject to the following two conditions: (1) this device may not cause harmful interference, and (2) this device must accept any interference received, including interference that may cause undesired operation.



Labeling of authorization
FCC ID: XEGCR-H101

Model for Canada

Compliance of radio transmitter

This device complies with Industry Canada's license-exempt RSSs. Operation is subject to the following two conditions:

- 1) This device may not cause interference; and
- 2) This device must accept any interference, including interference that may cause undesired operation of the device.

Labeling of authorization
IC: 1559C-CRH101

Compliance of interference

This Class B digital apparatus complies with Canadian ICES-003.

Model for EEA (European Economic Area)

This equipment complies with the harmonised standards of DIRECTIVE 1999/5/EC (R&TTE).

Labeling of conformity
CE marking:



CAUTION

Authorization of wireless devices are different in countries or regions. Please use only in the country where you purchased the product.

- Depending on the country, restrictions on the use of Bluetooth wireless technology might exist.

Radiation Exposure requirements

This equipment meets the regulation, which is recognized internationally, for the case of human exposure to radio waves generated by the transmitter.

Statement of compliance

Model for USA

This equipment complies with FCC radiation exposure limits set forth for an uncontrolled environment and meets the FCC radio frequency Exposure Guidelines.

Model for Canada

This equipment complies with IC RSS-102 radiation exposure limits set forth for an uncontrolled environment.

EEA (European Economic Area) model

This equipment complies with EN.62311; Assessment of electronic and electrical equipment related to human exposure restrictions for electromagnetic fields; the harmonised standard of DIRECTIVE 1999/5/EC.

CAUTION

Changes or modifications not expressly approved by the party responsible for compliance could void the user's authority to operate the equipment.

Information for interference (FCC requirements)

This equipment has been tested and found to comply with the limits for a Class B digital device, pursuant to Part 15 of the FCC Rules. These limits are designed to provide reasonable protection against harmful interference in a residential installation.

This equipment generates, uses, and can radiate radio frequency energy and, if not installed and used in accordance with the instructions, may cause harmful interference to radio communications.

However, there is no guarantee that interference will not occur in a particular installation.

If this equipment does cause harmful interference to radio or television reception, which can be determined by turning the equipment off and on, the user is encouraged to try to correct the interference by one or more of the following measures.

- Reorient or relocate the equipment and/or the receiving antenna.
- Increase the separation between the equipment and receiver.
- Connect the equipment into an outlet on a circuit different from that to which the receiver is connected.
- Consult the dealer or an experienced radio/TV technician for help.

Table of contents

Thank you for choosing TEAC product.
Read this manual carefully to get the best performance from this unit.
After reading it, keep it in a safe place for future reference.

IMPORTANT SAFETY INSTRUCTIONS	2
Wireless equipment precautions.....	5
Included accessories.....	6
Using the TEAC Global Site.....	6
Before use.....	7
Setting the clock.....	7
Notes about discs	8
Connections.....	10
Connecting speakers	12
Using the remote control.....	13
Names and functions of parts (remote control).....	14
Names and functions of parts (main unit)	16
Basic operation	17
Display information.....	21
Listening to CDs	23
Listening to FM radio	27
RDS (European model only).....	29
Playing back music on a computer.....	31
Bluetooth® function	33
Settings	34
Message list	36
Troubleshooting.....	37
Specifications.....	38

Included accessories

Check to be sure the box includes all the supplied accessories shown below.

Please contact the store where you purchased this unit if any of these accessories are missing or have been damaged during transportation.

Power cord × 1

Remote control (RC-1324) × 1

Batteries for remote control (AAA) × 2

Basic FM antenna × 1

Owner's manual × 1

- Keep this manual in a safe place for future reference.

Warranty card × 1 (for users in the USA and Canada only)

- Users in Europe and countries/regions other than the USA and Canada should see page 39 for information about the warranty.

Using the TEAC Global Site

You can download updates for this unit from the TEAC Global Site: <http://teac-global.com/>

- 1) Open the TEAC Global Site.
- 2) In the TEAC Downloads section, click the desired language to open the Downloads website page for that language.

NOTE

If the desired language does not appear, click Other Languages.

- 3) Click the "Search by Model Name" section to open the Downloads page for that product. (Users in Europe should click the product name in the "Products" section instead.)
- 4) Select and download the updates that are needed.

Before use

Placement of the unit

- Avoid placing it in high temperature environments such as in direct sunlight or close to a source of heat. Moreover, do not place the unit on an amplifier or any other device that generates heat. Doing so could cause discoloration, deformation or malfunction.
- Do not place anything on top of the unit. Do not put cloth on top of the unit or place it on top of bedding or thick carpet.

Maintenance

Wipe dirt from the top cover and other panel surfaces using a soft cloth that has been slightly dampened with a diluted neutral cleanser.

Do not use chemically-treated wipes, thinner or similar substances because they could damage the surface of the unit.

-  **For safety, disconnect the power cord from the outlet before cleaning.**

Setting the clock

This unit has a clock built-in.

After completing connections, set the current time.

The time appears on the display when, for example, the unit is in standby mode.

- See “Set clock (time settings)” on page 35 for how to set the clock.

Example of display when in standby

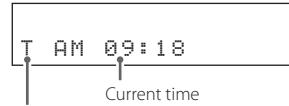

Appears when the on/off timer is on

- The clock will be reset if the unit's power cord is disconnected from an outlet. Reset the current time when you use the unit.
- The clock is not perfectly precise, so we recommend resetting the time occasionally.

Types of discs that can be played by this unit

CDs (12cm) with the Compact Disc Digital Audio logo



- This logo appears on disc labels and packaging.
- This unit cannot play 8cm CDs.

CD-R and CD-RW discs that have been properly recorded and finalized using the audio CD format. CD-R and CD-RW discs that have been written with MP3 or WMA files and finalized.

- Multi-session discs are not supported.

This unit cannot play discs of types other than those above.

⚠ If you try to play any other type of disc with this unit, loud noises that damage speakers or harm hearing could occur. Never try to play any type of disc other than those shown above.

- WMA files
Windows Media Audio Professional (WMA Pro) and Windows Media Audio Lossless (WMA Lossless) formats are not supported.
- Depending on the quality of the disc and the condition of the recording, playback might not be possible.
- This unit cannot read or play the following types of discs.
 - CD-ROM discs
 - Video CDs
 - Super Audio CDs
 - DVD video discs
 - DVD audio discs
 - DVD-ROM discs

⚠ If you load a DVD video, DVD audio, DVD-ROM or similar disc into this unit, the unit will try to play it and spin at high speed. If you accidentally load such a disc, the disc could be damaged, so do not try to remove it until it stops spinning.

- This unit might not be able to properly play Copy Control CDs, Dual Discs or other special CDs that do not conform to the Red Book CD standard. Operation and sound quality cannot be guaranteed when special discs are used in this unit. If playback of a special disc should cause trouble, contact the seller of the disc.

CD-R/CD-RW discs

This unit can play CD-R/CD-RW discs that are in audio CD format (CD-DA) or that contain MP3 or WMA format files.

- In order to play a disc created by a CD recorder, be sure to finalize it.
- Depending on the quality of the disc and the condition of the recording, playback might not be possible. For details, see the operation manual for the device you are using.
- If you have any questions about how to handle a CD-R or CD-RW disc, contact the seller of the disc directly.

Precautions for use

- Do not use cracked discs because they could damage the unit.
- Do not apply labels or other materials to discs. Do not use discs that have had tape, stickers or similar materials removed from them as they may have left a sticky residue on the disc's surface. Other discs to avoid are ones that have exposed glue around the edges of stickers, for example. Using such a disc in this unit could cause the disc to become stuck or could damage the unit.
- When writing something on the label side of a disc, use a felt tip permanent marker. The use of a ballpoint pen or other pen with a hard tip could damage the disc, making it unplayable.
- Never use commercially-available CD stabilizers. Doing so could make the disc unplayable or damage the unit.
- Never use discs with irregular shapes, including heart-shaped and octagonal discs, because they could damage the unit.

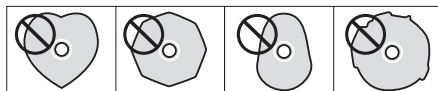

- To remove a disc from its case, while pressing down on the center of the case, hold the disc by its edges. Do not touch the side of the disc that has the data encoded on it (unlabeled side).

If a disc will not load properly

If a disc becomes caught or is otherwise difficult to insert, do not push it in forcefully. Press the eject (▲) button and remove the disc once before reinserting it. (Pushing a disc forcefully could damage the unit.)

Storing discs

- Discs should be stored in their cases when not being used. Failure to do so could result in warping and scratches.
- Do not leave discs in places that are exposed to direct sunlight or that are very humid or hot. Doing so could cause discs to become deformed or degraded, making them unplayable.
- CD-R and CD-RW discs are more susceptible to the impacts of heat and ultraviolet rays than ordinary CDs. For this reason, do not leave them for long times in places that are exposed to direct sunlight or near devices that generate heat, for example.
- Always clean discs before storing them. Leaving a disc in an unclean state might result in skipping or degraded sound quality.

Maintenance

- If the side of the disc that has the data encoded on it (unlabeled side) becomes dirty with fingerprints or dust, use a soft cloth to wipe the surface from the center directly toward the edge.



- Never use record cleaners, antistatic treatments, thinners or similar chemicals to clean discs. Such chemicals could harm the surface of the disc.

Connections

⚠ After all connections are complete, connect the power cord's plug to the AC wall outlet.

- Read the instructions of each device that you intend to use with this unit.
- Do not bundle connecting cables with power cords. Doing so could cause noise.
- Be sure to connect each plug securely.

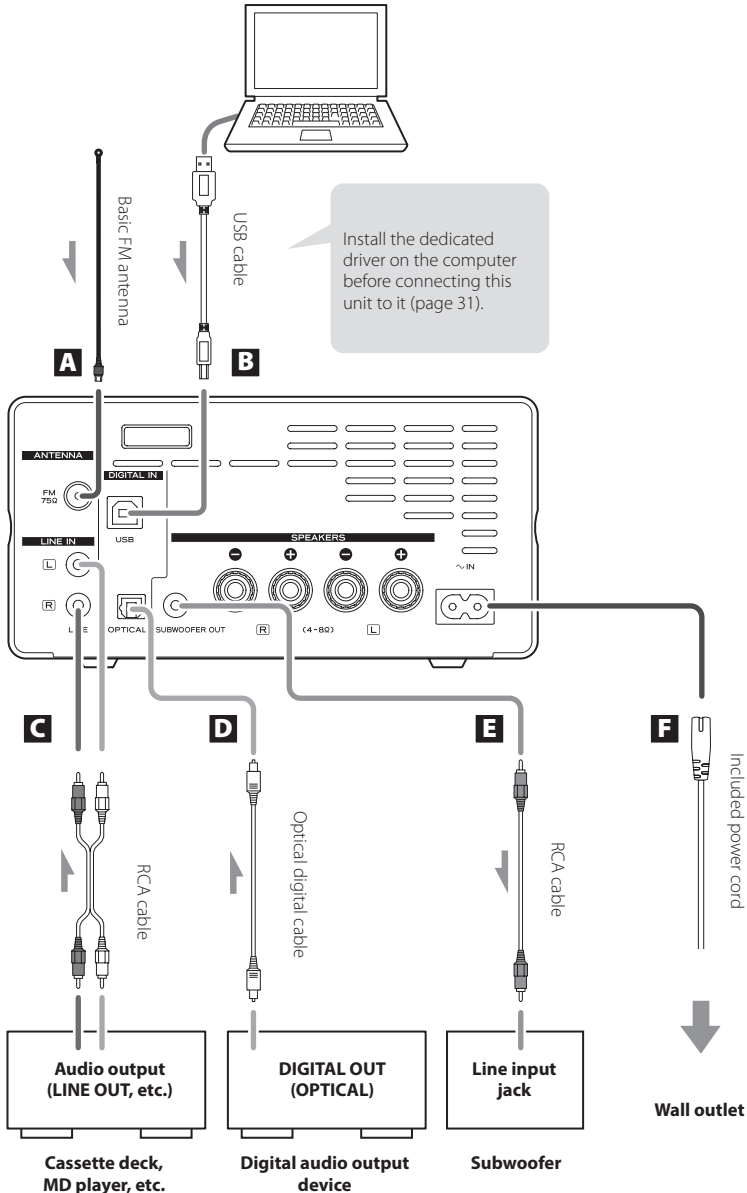

A FM antenna

When receiving an FM broadcast, extend this antenna and position it for the best reception. After moving this unit, readjust the position again.

B USB port

Use to input digital audio from a computer. Connect to the USB port of a computer to input digital audio from it.

Use a commercially-available USB cable.

ATTENTION

Install the dedicated TEAC driver software on the computer before connecting the unit (page 31).

C Analog audio input connectors (LINE IN)

Use these to input analog audio.

Connect an audio output device such as a cassette deck or MD player to these jacks using commercially-available RCA cables.

Use commercially-available cables for connections.

Connect the R connector of this unit to the right (R) connector of the audio output device and the L connector of this unit to the left (L) connector of the audio output device.

D Digital audio input connector (OPTICAL)

Input digital audio. Connect the digital audio output connector of a digital audio device to it.

Use a commercially-available optical digital (TOS) cable to make the connection.

- Sampling frequencies up to 192 kHz are supported.

E SUBWOOFER OUT connector

If you want to use a subwoofer, connect it to this connector.

- The output level is linked to the VOLUME controls on the front of the unit and on the remote control.

F Power inlet (~IN)

Insert the included power cord here.

After all other connections are complete, connect the power cord's plug to a wall outlet.

 **Do not use any power cord other than the one included with this unit. Use of other power cords could result in fire or electric shock. Unplug the cord from the outlet when not using the unit for a long time.**

Connecting speakers

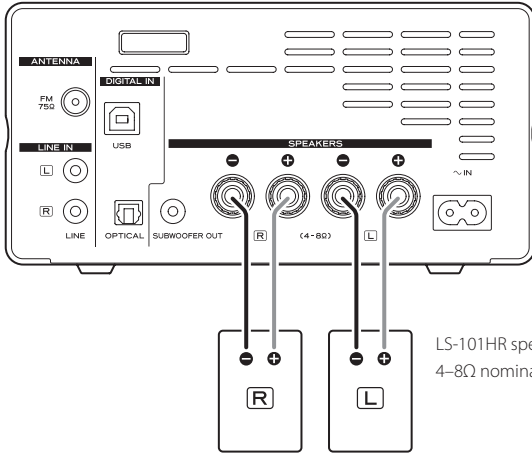

LS-101HR speakers or speakers with
4-8Ω nominal impedance

⚠ Precautions when making connections

- After all connections are complete, connect the power cord's plug to the AC wall outlet.
- Read the instructions of each device that you intend to use with this unit.

CAUTION

- When not connecting LS-101HR speakers, use speakers with 4-8Ω nominal impedance. If speakers with different impedance ratings are used, the protection circuit could operate, causing sound output to stop.
- The red speaker terminals are positive (+) and the black speaker terminals are negative (-). Generally, the + wire of the speaker cable is marked to distinguish it from the - wire of the cable. Connect the marked wire to the red + terminal and the unmarked wire to the black - terminal.
- The metal portions of the two separate wires should not touch. If they touch an electrical short might occur. Shorted wires can create a fire hazard or cause equipment failure.
Never allow speaker cables to cause a short.
- Be sure to insert each plug securely. To prevent hum and noise, avoid bundling the cables together with the AC power cord or other cables.

How to connect speakers

- 1 Turn the terminal cap counterclockwise to loosen it. The speaker terminal caps cannot be fully removed from the unit.**
- 2 Insert the wire into the terminal and turn the terminal cap clockwise to securely connect it.**

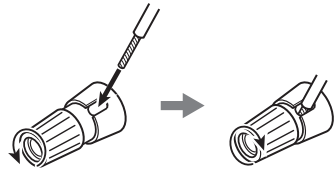

- Make sure none of the wire insulation is under the terminal and only the bare, stripped wire is touching the terminal.
- 3 Confirm that the cable is fastened securely by gently pulling the cable.**

Connecting with banana plugs

You can also make connections using commercially-available banana plugs. First, connect the banana plugs to the speaker cables and then connect the plugs to the terminals.

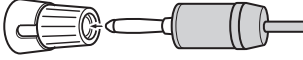

- Keep the caps tightened when in use.
- Carefully read the instructions for the banana plugs that you are using.

Notice about the European model

In accordance with European safety regulations, connecting banana plugs to speaker terminals is not allowed on European models. The holes into which banana plugs could be inserted have been covered with black caps. Connect speakers using bare wires or spade lugs. If a black cap should become separated from its terminal, return it to its original position.

Precautions for use

⚠ Misuse of batteries could cause them to rupture or leak leading to fire, injury or the staining of items nearby. Please read and observe the precautions on page 3 carefully.

- When using the remote control, point it toward the remote control signal receiver on the main unit from a distance of 5 m (16 ft) or less. Do not place obstructions between the main unit and the remote control.
- The remote control might not work if the remote control signal receiver on the main unit is exposed to sunlight or bright lights. In this case, try moving the main unit.
- Beware that use of this remote control could cause the unintentional operation of other devices that can be controlled by infrared rays.

Installing batteries

Remove the cover on the back of the remote control, and insert 2 AAA batteries into the case, aligning them with the ⊕ and ⊖ indications. Replace the cover.

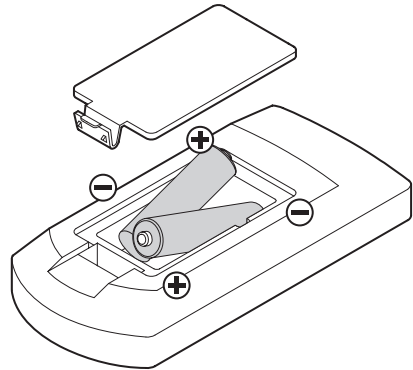

Battery Replacement

If the operation range of the remote control decreases, the batteries have become exhausted. In this case, replace the batteries with new ones.

Dispose of the used batteries according to the instructions on them or requirements set by your local municipality.

Names and functions of parts (remote control)

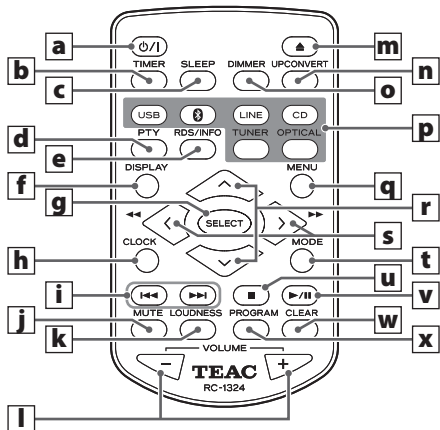

When both the main unit and the remote control have buttons with the same functions, the instructions in this manual refer only to one, but the other can be used in the same way.

a Standby/on (⏻/⏻) button

Press this button to turn the unit on and put it in standby. When the unit is ON, the ring around the main unit STANDBY/ON (⏻/⏻) button lights blue.

b TIMER button

Use to set the on/off timer.

c SLEEP button

Use to set the sleep timer.

d PTY button

Use to search for stations by program type (PTY). This button does not work at all on the USA/Canadian model.

e RDS/INFO button

When the playback source is FM, use this button to select an RDS mode. Please ignore "INFO" on the remote control unit. (INFO function does not work on this unit.)

This button does not work at all on the USA/Canadian model.

f DISPLAY button

Press to change what is shown on the display.

g SELECT button

Use to change settings.

h CLOCK button

Press repeatedly to show the time and the on/off timer setting, and then return to showing the previous information on the display.

i Skip (⏮/⏭) buttons

When the playback source is CD, use to skip to the previous or next track.

When the playback source is FM, use to change presets.

j MUTE button

Press this button to mute the sound temporarily. To restore the sound, press it again.

k LOUDNESS button

Press to turn low-frequency emphasis on and off. When on, the  icon appears on the display.

l VOLUME (-/+ buttons)

Use these to adjust the volume.

m Eject (⏏) button

Press to partially eject the disc. Hold the disc by its edges and pull it out.

n **UPCONVERT button**

Press this button to turn upconversion on and off.

o **DIMMER button**

Press to change the display brightness.

p **Source buttons**

Use these buttons to select the playback source.

q **MENU button**

Press to enter setting mode.

r **Direction (^/∨) buttons**

When the playback source is CD, use to select folders.
(MP3/WMA only)

When the playback source is FM, use to change presets.

s **Direction (</>) buttons**

Search (◀/▶) buttons

When the playback source is CD, press during playback to search backward/forward.

When the playback source is FM, use to lower/raise the frequency received. Press and hold for at least two seconds to begin automatically selecting stations.

t **MODE button**

When the playback source is CD, use to switch between repeat playback and shuffle playback.

When the playback source is FM, use to switch between stereo and mono.

u **Stop (■) button**

Press during playback to stop playback.

v **Play/pause (▶/||) button**

When the playback source is CD and the unit is stopped or paused, press to start disc playback.

Use this button to pause playback during playback.

When the playback source is FM, use to select presets and frequencies.

w **CLEAR button**

Use to clear programmed tracks.

x **PROGRAM button**

When the playback source is CD, use with program playback.

When the playback source is FM, use with radio station presets.

Names and functions of parts (main unit)

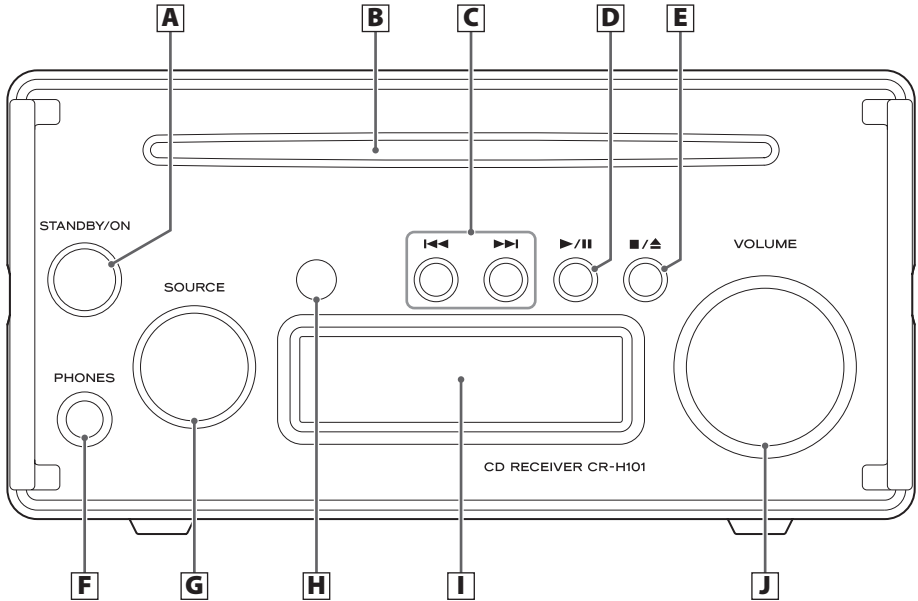

A STANDBY/ON (⏻/⏻) button

Press this button to turn the unit on and put it in standby. When the unit is ON, the ring around the button lights blue.

- When this unit is in standby mode, it consumes standby power. For this reason, we use the term “standby” rather than “off”.

B Disc slot

Insert a disc here. After a disc is inserted partway, the unit will automatically draw it in.

C Skip (⏮/⏭) buttons

When the playback source is CD, use to skip to the previous or next track. During playback, press and hold to search backward/forward.

D Play/pause (▶/⏸) button

When paused, press to resume playback. Press during playback to pause. Press again to resume playback.

E Stop/eject (■/▲) button

Press during playback to stop playback. When stopped, press to partially eject the disc. Hold the disc by its edges and pull it out.

F PHONES jack

Connect headphones (3.5mm stereo mini plug) here.

- When headphones are connected to the unit, audio will not be output from the SPEAKERS terminals on its back.

G SOURCE knob

Turn to select the playback source.

H Remote control signal receiver

Receives signals from the remote control. When operating the remote control, point it at this sensor.

I Display

This shows a variety of information.

J VOLUME knob

Use this knob to adjust the volume. To increase the volume, turn the knob clockwise. To decrease the volume, turn the knob counterclockwise.

- When the volume is adjusted with the remote control, the main unit volume knob will not turn in response.

Basic operation

Turning the unit on/off (standby)

Press the STANDBY/ON (⏻/⏻) button to turn the unit on. The indicator lights blue when on.

Press the button again to put the unit in standby. The indicator becomes unlit.

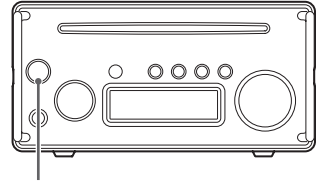

STANDBY/ON



Changing the playback source

Turn the SOURCE knob to select the playback source.

The name of the selected playback source is shown.

Turn the SOURCE knob clockwise to change the playback source in the following order.

▶ USB → Bluetooth → LINE → CD → FM → OPTICAL

- If a digital audio format other than PCM is input, "No Signal" will be shown and no sound will be output. If this is the case, the connected digital audio output device might have a "PCM" digital output format setting that would enable playback. Refer to the operation manual for that device to make this setting.

- To use this unit with a Windows computer, you must install the dedicated driver on that computer before setting this unit to USB and playing audio files on the computer (page 31).

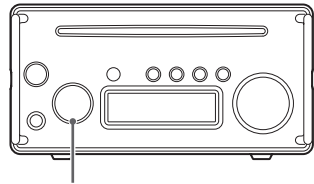

SOURCE

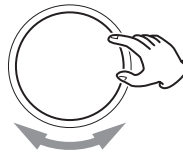

Adjusting the volume

Turn the VOLUME knob or use the VOLUME buttons on the remote control to adjust the volume to the appropriate level.

- The volume setting will be shown when you turn the VOLUME knob. As the value increases, the volume becomes louder.

Display example

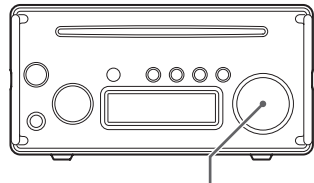
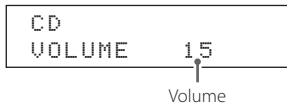

VOLUME

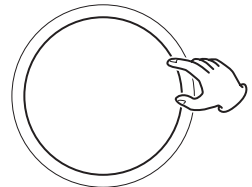

MIN: Minimum volume
MAX: Maximum volume

Basic operation (continued)

Upconversion

You can use the upconversion function with digital input (USB, Bluetooth, CD, OPTICAL).

Press the UPCONVERT button on the remote control to enable the upconversion function. The  icon will appear on the display.

Input sampling frequencies and sampling frequencies after upconversion

Input sampling frequency	Sampling frequency after upconversion
44.1 kHz	88.2 kHz
48 kHz	96 kHz
88.2 kHz	176.4 kHz
96 kHz	192 kHz
176.4 kHz	176.4 kHz
192 kHz	192 kHz

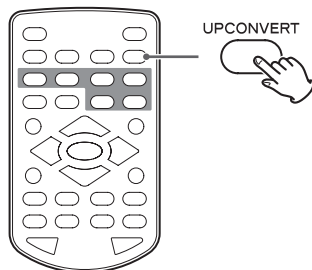

HR loudness

Press the remote control LOUDNESS button to turn low-frequency emphasis on and off. When on, the  icon appears on the display.

Since this uses high-resolution (192kHz/24-bit) digital audio processing, it can enhance low frequencies without degrading the audio quality.

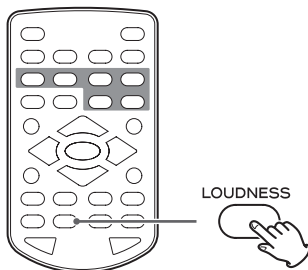

Muting playback

If you want to temporarily mute the volume of this unit, press the MUTE button on the remote control.

"MUTING" appears on the display when muted.

Display example

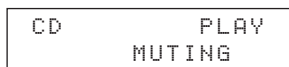

Press the MUTE button on the remote control again to return to the previous volume level.

- Muting will stop if you change the playback source or use the VOLUME knob or remote control VOLUME buttons (-/+).

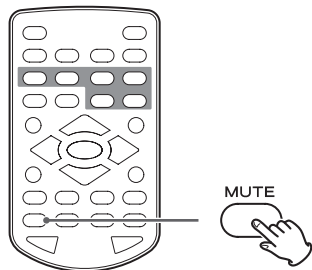

Dimmer

Press the remote control DIMMER button to cycle through display brightness levels.



- This setting is retained when the unit is in standby.

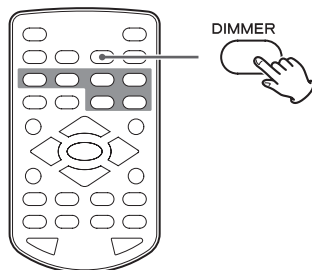

On/off timer

The unit can turn on/off (standby) at a set time.

- Confirm that the unit's clock is set correctly in advance.
- Use the included remote control to set the timer.

Setting the on/off time

1 Press the **TIMER** button.

2 Press a direction (</>) button to show "2.Setting", and press the **SELECT** button.

```
Timer MENU
< 2.Setting >
```

3 Set the time to turn the unit on.

The hour position blinks. Use the direction (∧/∨) buttons to set the hour of the on time and press the **SELECT** button. Next, the minute position blinks. Set it in the same manner.

Display example

```
On Time
AM 07:00
```

4 Set the time to turn the unit off (standby).

Display example

```
Off Time
AM 08:00
```

5 Select the playback source.

Use the direction (∧/∨) buttons to select the playback source (CD or TUNER) and press the **SELECT** button.

Display example

```
Select source
CD
```

- If you select CD, load a CD before putting the unit in standby.

6 Set that playback volume.

Use the direction (∧/∨) buttons to set the volume and press the **SELECT** button.

Display example

```
Select volume
Volume 23
```

7 Press the **TIMER** button to complete making settings.

Be sure to set the Timer ON/OFF setting to ON to make the unit turn on/off at the set times.

Turning the timer function on/off

1 Press the **TIMER** button.

- When the unit is at its factory default settings before on and off times have been set, if you press the **TIMER** button, "First Timer Set" will appear on the display. You must set these before proceeding.

2 Press a direction (</>) button to show "1.ON/OFF", and press the **SELECT** button.

```
Timer MENU
< 1.ON/OFF >
```

3 Press a direction (∧/∨) button to turn the timer on or off and press the **SELECT** button.

Display example

```
Timer MENU
Timer ON
```

4 Press the **TIMER** button to complete making settings.

5 Press the **STANDBY/ON** (⏻/⏻) button to put the unit into standby.

- When the timer is set to ON, "T" will be shown at the bottom left of the display when the unit is put in standby (page 7).
- If the unit is already on, the timer will not function at the scheduled times. Always put the unit into standby to enable the timer to function.
- If the playback source is CD, but no CD is loaded, the FM radio will play instead.

Basic operation (continued)

Checking the timer setting

Press the CLOCK button to show the current time and then the timer setting.

Display example

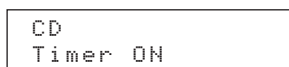

Using the sleep timer

This function puts the unit in standby after a set amount of time passes. Press the SLEEP button to set the amount of time (in minutes) until the unit enters standby.



When the sleep timer is enabled, the display becomes dim.

Display example

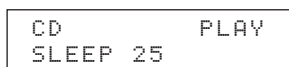

When the sleep timer is enabled, press the SLEEP button once to show the amount of time until standby for a few seconds.

Press it again to reset the time.

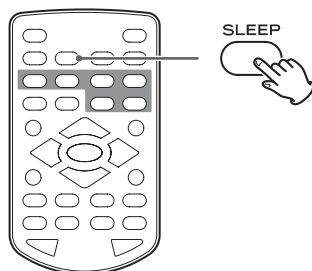

Automatic power saving function

This unit has an automatic power saving function.

The operation of this function depends on the automatic power saving setting and the selected playback source.

- See “APS (automatic power saving) setting” on page 35 for how to set the automatic power saving function.

When automatic power saving is on

If there is no signal from the selected playback source and no operation has occurred for about 30 minutes, the unit will enter standby mode.*

- Turn the unit on again to end standby.

*Power consumption in standby mode is 1 W or less.

Checking whether automatic power saving is on or off

When automatic power saving is on

“APS ON” is shown when the unit is turned on.

When automatic power saving is off

“APS OFF” is shown when the unit is turned on.

Display information

Press the DISPLAY button to change the information shown on the display.

- The display contents shown below are examples.

External input

Press the DISPLAY button to change the information shown on the display for about two seconds.

When set to USB or OPTICAL

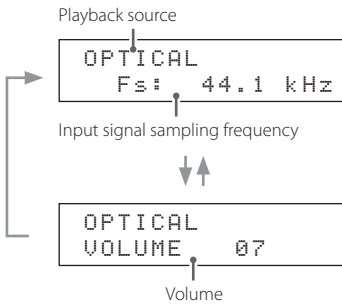

When set to LINE or Bluetooth

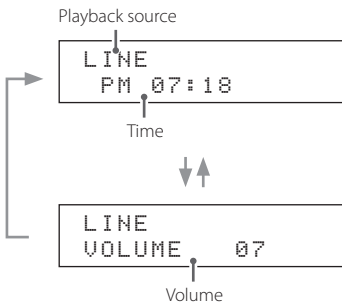

FM

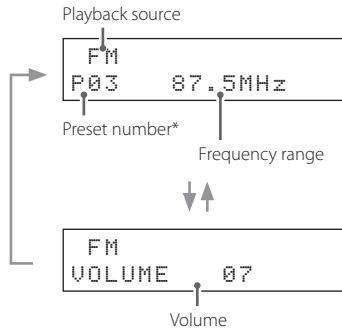

*This appears when a preset is selected.

- The FM information (shown above) cannot be changed on the European model.

Display information (continued)

CD

Audio CD

Stopped

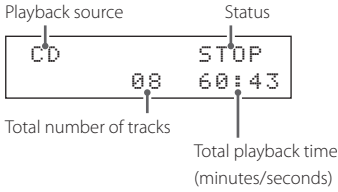

Playing back

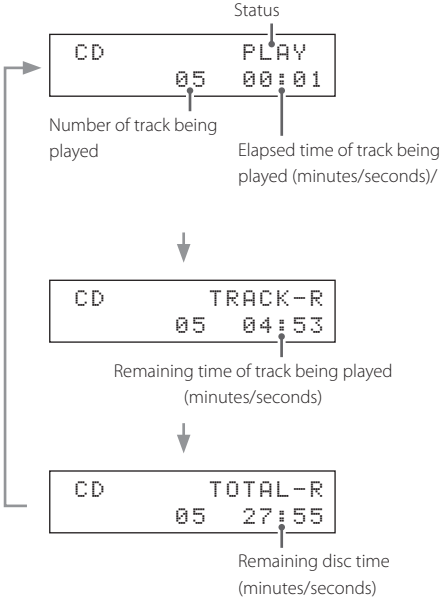

Disc with audio files

Stopped

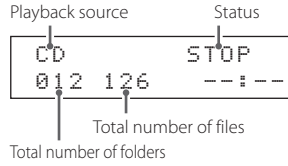

Playing back

When playback starts, the data format appears followed by the status

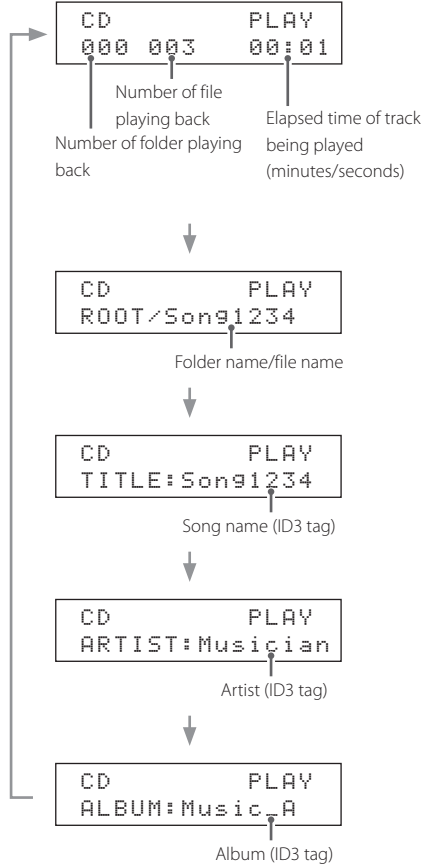

The root folder is shown as "ROOT".

- If the information does not fit in one line, it will scroll.

Playing a CD

1 Hold the disc by its edges with the labeled side up and insert it partway.

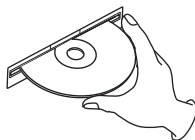

2 Push the disc in further until just before it disappears. It will automatically be drawn in to the slot.

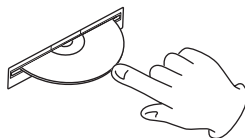

3 Press the play/pause (▶/||) button.

During playback, PLAY appears at the top of the display.

- If CD Auto Start is ON when a CD is loaded, the playback source will be set to CD and playback will start automatically (page 35).

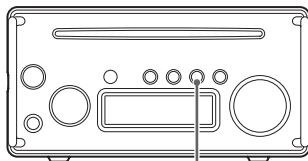

Pausing playback

Press the play/pause (▶/||) button to pause playback.

To resume playback from the position where it was paused, press the play/pause (▶/||) button again.

When paused, PAUSE appears at the top of the display.

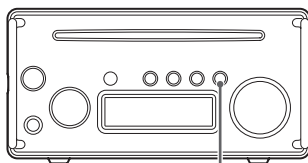

Stopping playback

Press the stop/eject (■/▲) button to stop playback.

Ejecting a disc

When CD playback is stopped, press the stop/eject (■/▲) button.

Press to partially eject the disc. Hold the disc by its edges and pull it out.

- Pressing the stop/eject (■/▲) button will eject the disc regardless of the selected playback source.

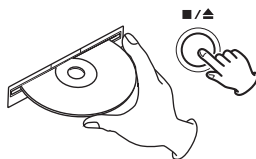

Skipping to search for a track

Press a skip (◀◀/▶▶) button to skip to the previous or next track. Keep pressing until you reach the track you want.

- During playback, press the ◀◀ button once to return to the beginning of the current track. When you want to play an earlier track, press the ◀◀ button repeatedly until you reach that track.
- During program playback, tracks from earlier or later in the program will be played back.

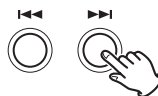
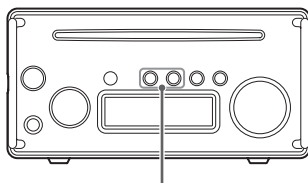

Searching for part of a track

Press and hold a skip (◀◀/▶▶) button on the unit to search backward/forward. Release the button when you find the desired part.

With the remote control, press and hold a direction (</>) button to search backward/forward. Release the button when you find the desired part.

Selecting and playing tracks on a disc that contains audio files

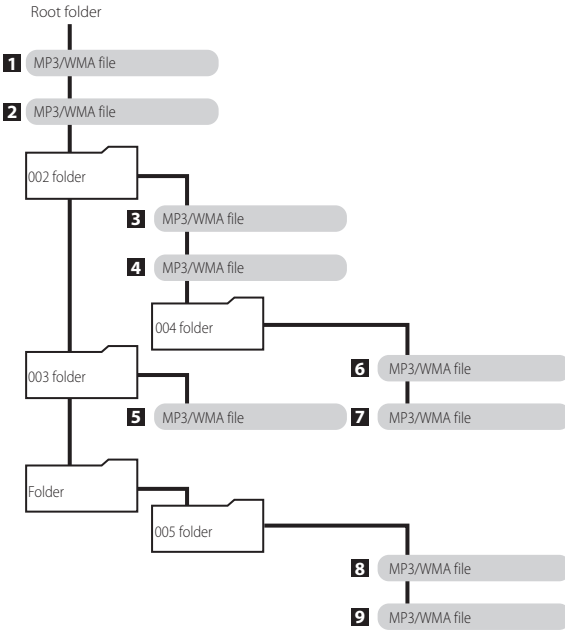

1 - 9 is the order of file playback.

Repeat/shuffle playback

Each time you press the MODE button on the remote control, the repeat/shuffle mode changes as shown in the illustration.

- During program playback, only repeating all tracks is possible.

**RP-FOLDER* does not appear during music CD playback.

Conduct the following operations when stopped.

Moving between folders

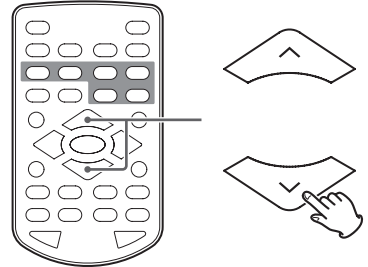

Selecting files

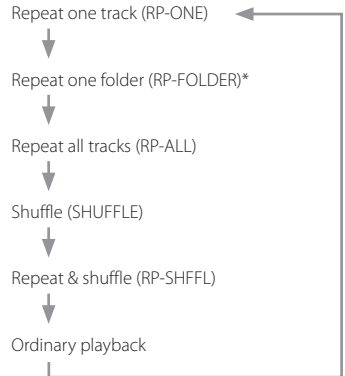
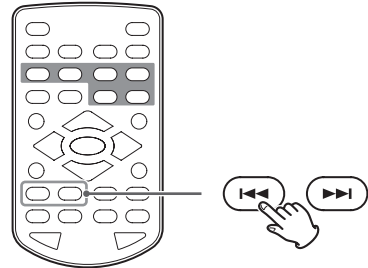

Program playback

Program playback is only possible with audio CDs.

Any of the following operations will clear all the tracks from the program.

- Ejecting the disc
- Using the STANDBY/ON button on the unit to put it into standby

Using program playback

1 Press the PROGRAM button.

MEM and the track number blink.

- Press when stopped.

2 Use the skip (◀◀/▶▶) buttons to select a track and press the SELECT button to add it to the program.

- Repeat to add more tracks as desired.
- You can also press the PROGRAM button to add a track.

3 Press the play/pause (▶/||) button to start program playback.

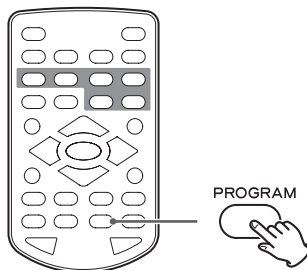

Example display

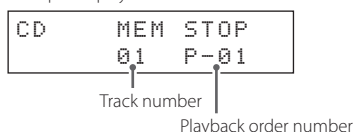

Checking and changing the program

1 Press the PROGRAM button.

MEM and the playback order number blink.

Display example

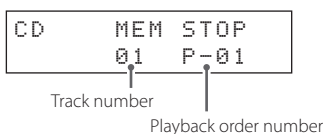

2 Use the skip (◀◀/▶▶) buttons to change the playback order number shown and check the track number.

Changing the program

- 1) Show the playback order number of the track that you want to change.
- 2) Press the PROGRAM button.
- 3) Select a track and press the PROGRAM button to add it to the program in place of the original track.

Removing a track from the program

- 1) Show the playback order number of the track that you want to remove.
- 2) Press the CLEAR button.

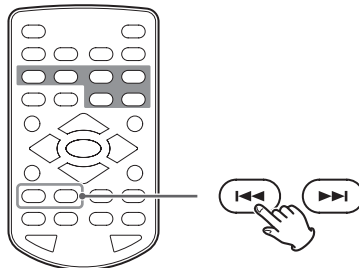
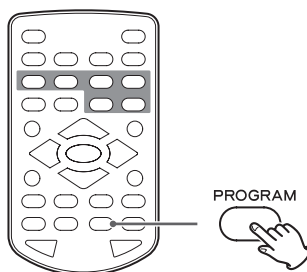

Listening to CDs (continued)

- Press the play/pause (▶/||) button to start program playback.

NOTE

To start program playback again after stopping, press the PROGRAM button and then the play/pause (▶/||) button.

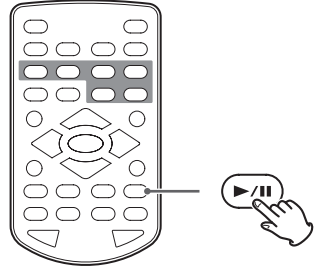

Adding tracks to the program

- Press the PROGRAM button.

MEM and the track number blink.

- Select a track and press the PROGRAM button to add it to the program.

- Repeat to add more tracks as desired.

- Press the play/pause (▶/||) button to start program playback.

Removing all tracks from the program

- When stopped, press and hold the CLEAR button.

- When "Program clear?" appears, press the SELECT button to remove all tracks from the program.

Display example

```
CD          STOP
Program clear?
```

To cancel the operation, press the stop (■) or CLEAR button.

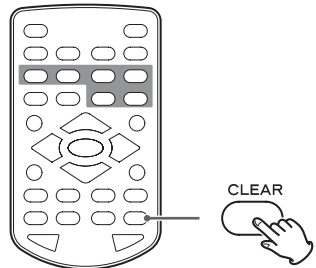

Listening to FM radio

FM mode

Press the MODE button to switch between stereo and mono reception.

Display example

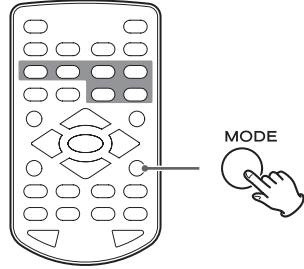
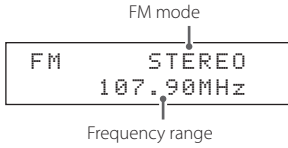

STEREO

Receive stereo FM broadcasts in stereo.

- "STEREO" will be shown when receiving in stereo.

MONO

Receive FM broadcasts in mono. When the reception of an FM stereo broadcast is poor, select this mode. The sound becomes mono, but noise is also reduced, making it sound better.

Changing the received frequency

Increasing the received frequency

Press the direction (>) button to increase the received frequency one step. Press and hold the direction (>) button to search for a station in the higher-frequency direction.

Decreasing the received frequency

Press the direction (<) button to decrease the received frequency one step. Press and hold the direction (<) button to search for a station in the lower-frequency direction.

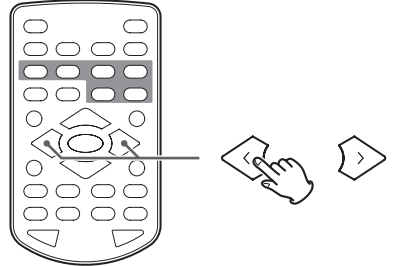

Broadcast station presets

This unit can have up to 20 FM station presets.

Setting presets manually

- 1** Tune in the station that you want to add as a preset.
- 2** Press the PROGRAM button.
- 3** Use the skip (|◀◀/▶▶|) buttons to select the preset number to assign to that station.
An * appears to the right of preset numbers that already have station assignments.
- 4** Press the PROGRAM or SELECT button to save the preset.

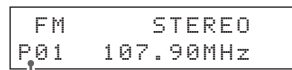

- Preset numbers between 01 and 20 can be assigned.

Listening to FM radio (continued)

Setting presets automatically

The unit can automatically search for stations that it can receive and assign them to preset numbers.

Press and hold the PROGRAM button.

The unit will search for stations from the lowest receivable frequency to the highest and assign them to preset numbers.

- After 20 presets have been assigned, "Full" will blink on the display and automatic preset assignment will stop.

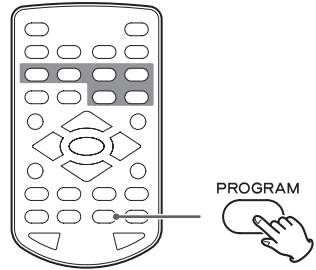

Selecting presets

Use the direction (^/∨) buttons to change the preset number.

Display example

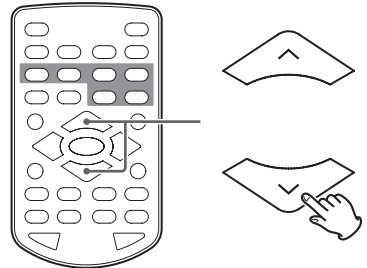
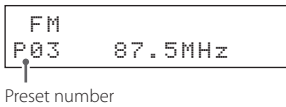

Selecting presets using the main unit

Press the play/pause (▶/||) button to switch between preset selection and frequency selection.

Press the play/pause (▶/||) button to show a preset number on the display, and use the skip (◀◀/▶▶) buttons to change the preset number.

- When a preset number is not shown, you can use the skip (◀◀/▶▶) buttons to change the reception frequency.

RDS (European model only)

The Radio Data System (RDS) is a broadcasting service that allows stations to send additional information along with the regular radio program signal.

- **RDS works on the FM frequency band in Europe only.**

1 Tune in to an FM RDS station (page 17).

2 Press the remote control RDS button.

Pressing the RDS button cycles through RDS modes as follows:

Program service (PS)

When you select Program service, "PS" will appear to the right of "FM" and then the program service name or station's name will be displayed. If there is no program service data, the frequency will be displayed.

RDS Program type (PTY)

When you select RDS Program type, "PTY" will appear to the right of "FM" and then the program type will be displayed.

RDS Radio text (RT)

When you select RDS Radio text, "RT" will appear to the right of "FM" and then information from the station consisting of up to 64 characters will be displayed.

RDS Clock time (CT)

Displays time information provided by the station.

- This setting is disabled when the unit is shipped new from the factory.

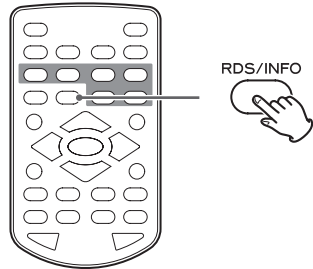

The clock setting of this unit is automatically adjusted according to the RDS Clock time (CT) data it receives.

To turn on automatic clock adjustment, hold down the RDS button for more than 8 seconds.

- When automatic clock adjustment is enabled, the unit adjusts its clock in response to received CT data no matter which RDS mode is selected.

If you tune in an RDS station that is broadcasting incorrect CT data, the clock might be incorrectly adjusted. This could eventually affect timer operation.

If you do not want the clock of this unit to be set according to received CT data, turn off automatic clock adjustment.

To turn off automatic clock adjustment, hold down the RDS button for more than 8 seconds.

PTY search

You can search for stations by program type. This function is available only through the RDS services of FM frequency stations in Europe.

1 Press the PTY button.

"PTY SEARCH" appears on the display.

```
FM    PTY SEARCH  
< NEWS >
```

2 Use the direction (^/∨) buttons to select the desired program.

You can select from 31 program types (PTY).

3 Press the SELECT button.

The unit starts searching.

- When the program type that you have selected is found, searching stops and the program type will be displayed.
- If a matching program type is not found during PTY Search, it will stop at the frequency set before searching started.
- If you want to stop searching, press the PTY button.

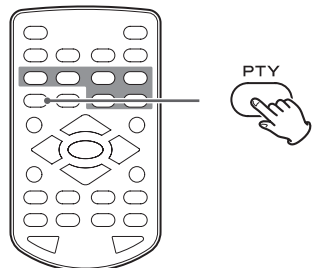

RDS (European model only) (continued)

NEWS:

Brief announcements, events, public opinion, reports and real situations.

AFFAIRS:

Suggestions, including practical announcements other than news, documents, discussion and analysis.

INFO:

Useful and reference information, such as weather forecasts, consumer guides and medical advice.

SPORT:

Sports-related programs.

EDUCATE:

Educational and cultural information.

DRAMA:

All kinds of radio concerts and serial dramas.

CULTURE:

All aspects of national or local culture, including religious events, philosophy, social science, language and theatre.

SCIENCE:

Programs on natural science and technology.

VARIED:

Popular programs such as quizzes, entertainment news, interviews, comedy and satire.

POP M:

Programs of commercial and popular songs, including music sales volumes, etc.

ROCK M:

Modern music generally composed and played by young musicians.

EASY M:

Popular music usually lasting for less than 5 minutes.

LIGHT M:

Classical music, instrumental music, chorus, and light music favored by general audiences.

CLASSICS:

Orchestral music including great operas and symphonies, chamber music and so on.

OTHER M:

Other music styles, including rhythm & blues and reggae.

WEATHER:

Weather reports and forecasts.

FINANCE:

Financial reports, commerce and trading.

CHILDREN:

Children's programs.

SOCIAL:

Social affairs.

RELIGION:

Religious programs.

PHONE IN:

Programs in which the public expresses its views by phone.

TRAVEL:

Travel reports.

LEISURE:

Programs concerning recreational activities.

JAZZ:

Jazz music.

COUNTRY:

Country music.

NATION M:

National music.

OLDIES:

Music from the so-called golden age of popular music.

FOLK M:

Folk music.

DOCUMENT:

Documentaries.

TEST:

Broadcast when testing emergency broadcast equipment or receivers. Not intended for searching or dynamic switching for consumer receivers.

ALARM:

A program with notifications about emergencies and natural disasters.

Playing back music on a computer

Installing the driver on a computer

This unit can be connected by USB and used with a computer running one of the following operating systems. Operation is not guaranteed with operating systems other than the following (As of September 2015).

Mac OS

The unit works with the following versions.

OS X Lion 10.7

OS X Mountain Lion 10.8

OS X Mavericks 10.9

OS X Yosemite 10.10

This unit can be operated with the standard OS driver, so there is no need to install a driver.

Windows OS

The unit works with the following versions.

Windows 7 (32/64-bit)

Windows 8 (32/64-bit)

Windows 8.1 (32/64-bit)

Windows 10 (32/64-bit)

Installing the driver on the computer

Before you can use this unit to play files on a Windows computer, you must first download the dedicated driver from the TEAC Global Site and install it on the computer.

TEAC Global Site

<http://teac-global.com/>

ATTENTION

Install the dedicated driver software on the computer before connecting the unit by USB.

If a computer is connected to this unit before the driver is installed, proper operation will not be possible.

- For instructions about driver installation procedures, please access the Downloads page from the TEAC Global site (<http://teac-global.com/>).
- Depending on the combination of hardware and software, proper operation might not be possible even with the above operating systems.

About the transmission mode

This unit connects using high-speed asynchronous mode. Transmittable sampling frequencies are 44.1 kHz, 48 kHz, 88.2 kHz, 96 kHz, 176.4 kHz and 192 kHz.

When properly connected, you will be able to select "TEAC USB AUDIO DEVICE" as an audio output from the computer.

- In asynchronous mode, the audio data sent from the computer is processed using this unit's clock, reducing data transmission jitter.

Downloading the TEAC HR Audio Player application

Our TEAC HR Audio Player application (Mac and Windows versions available) supports playback of high-resolution audio files. You can download it from TEAC Global Site.

TEAC Global Site

<http://teac-global.com/>

- This unit does not support the playback of DSD files.

Playing back music on a computer (continued)

Playing back audio files from a computer

1 Connect this unit to the computer using a USB cable.

- To use a Windows computer, you must install the dedicated driver beforehand (page 31).
 - No driver is necessary when using a Mac computer.
- Use a USB cable with a connector that matches that of this unit.

2 Turn the computer on.

- Confirm that the computer has started up correctly.

3 Press the **STANDBY/ON** (⏻) button to turn the unit on.

4 Turn the **SOURCE** knob to select **USB**.

5 Start playback of an audio file on the computer.

If you can adjust the volume from the computer, set it to its maximum level and use this unit's **VOLUME** knob to adjust the level for the best audio quality.

- If you are using the TEAC HR Audio Player Application, the volume cannot be adjusted from the computer.

Turn this unit's **VOLUME** knob to **MIN** before starting playback. Then, gradually turn it up.

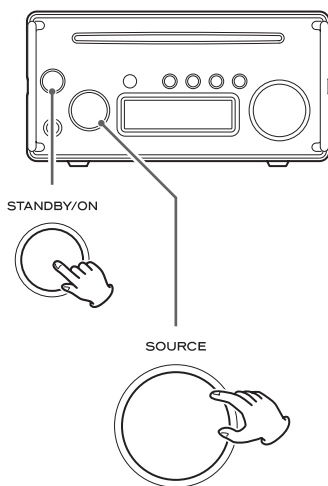
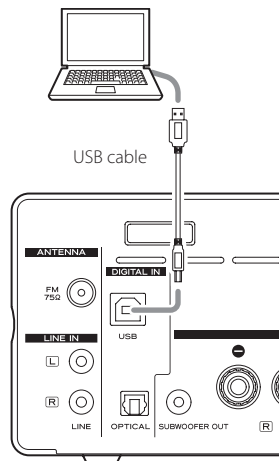

- The computer and this unit cannot control each other.

- Do not do any of the following when playing back an audio file via USB. Doing so could cause the computer to malfunction. Always quit the music playback software before doing any of the following.

- Disconnect the USB cable
- Put the unit into standby
- Change the playback source

- When playing back an audio file via USB, computer operation sounds will also be output. If you do not want these sounds to be output, make appropriate settings on the computer to turn them off.

- If you connect this unit with the computer or you set the playback source to USB after starting music playback software, music files might not play back properly. If this occurs, restart the music playback software or restart the computer.

Bluetooth notes

When using this unit with a mobile phone or other Bluetooth devices, they should be no more than about 10 m (33 ft) apart. Depending on the circumstances of use, however, the effective transmission distance might be shorter.

Wireless communication with every device that supports Bluetooth wireless technology is not guaranteed.

To determine the compatibility between this unit and another device that supports Bluetooth wireless technology, refer to that device's operation manual or contact the shop where you purchased it.

1 Turn the SOURCE knob to select Bluetooth.

Display example

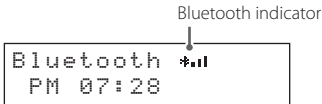

2 Pair or connect with another Bluetooth device.

Pairing with another Bluetooth device

Pairing this unit with another Bluetooth device is necessary the first time you connect with that Bluetooth device.

If no paired Bluetooth device is found, this unit will become ready to pair with another device. When this unit is ready to pair, its Bluetooth indicator blinks.

When this unit's Bluetooth indicator is blinking, conduct pairing using the other Bluetooth device.

For details, refer to the operation manual of that Bluetooth device.

When pairing with a Bluetooth device that supports aptX® or AAC, it will automatically connect using aptX or AAC.

Connecting with an already paired Bluetooth device

When the playback source of this unit is set to Bluetooth and the other Bluetooth device is on, the Bluetooth function will be enabled and they should connect automatically.

If they do not connect automatically, connect them manually.

- If a request for a passcode appears on the screen of the Bluetooth device, enter "0000" (four zeros).
- When this unit and the other Bluetooth device are connected, the Bluetooth indicator stops blinking and stays lit.
- When pairing or connecting with another Bluetooth device, they should be within a few meters of each other. If they are too far apart, pairing and connection afterwards might become impossible.
- When Bluetooth is selected as the playback source for this unit, the Bluetooth device that was last connected to it will automatically be connected again. If you want to connect with a different Bluetooth device, conduct pairing with that device.
- This unit will store information for up to eight pairable devices. If more than eight devices are paired, the oldest pairing information will be deleted and the new pairing information will be added.

⚠ ATTENTION

Even when this unit or the other Bluetooth device is ready to connect, if the Bluetooth indicator on this unit continues to blink for 10 minutes, it will automatically enter standby mode. To use this unit, you must turn it on again.

If the indicator continues blinking for a long time, restart both this unit and the other Bluetooth device and then reconnect them.

3 Start playback on the other Bluetooth device.

- Confirm that the volume is turned up on the other Bluetooth device. If you do not turn up the volume on the playback device, no sound might be output from this unit.
- Depending on the connected Bluetooth device, you might not be able to adjust the volume. For details, refer to the operation manual of that Bluetooth device.

Warning about Bluetooth device operation

You can use the following buttons on the main unit or the remote control to control a connected Bluetooth device.

Play/pause (▶/⏸) button

Skip (⏮/▶) buttons

- Depending on the Bluetooth device being used, it might not respond to remote control operations and actual operations could differ.

1 Press the MENU button.

2 Use the direction (</>) buttons to change the setting item and press the SELECT button.

Display example

```
Menu
< 1.Set clock >
```

Press the > button to cycle through the following items.

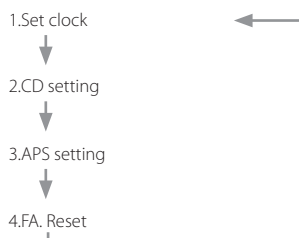

Press the < button to cycle through these items in reverse order.

3 Use the direction (^/∨) buttons to change the setting, and press the SELECT button to confirm the change.

Display example

```
Current Time
12H/24H
```

The selected item blinks.

- When there are multiple settings, press the SELECT button to show the next setting.

Repeat procedures **2-3** to set other items as necessary.

- Press the MENU button instead to cancel the setting change.

4 Press the MENU button to complete making settings.

Set clock (time settings)

Set the clock in the following manner.

Current Time (time display)

Select 12-hour or 24-hour display.

Display
example

```
Current Time
12H/24H
```

Current Time (time shown)

Set the current time in order of hours and minutes.

Display
example

```
Current Time
PM 11:45
```

1 Use the direction (∧/∨) buttons to select "12h" or "24h", and press the SELECT button.

2 Use the direction (∧/∨) buttons to input the hour, and press the SELECT button.

3 Use the direction (∧/∨) buttons to input the minute, and press the SELECT button.

This completes setting the time.

CD setting

CD Auto Start

- This is set to OFF when shipped new from the factory.

OFF: CD will not automatically play when loaded.

ON: CD will automatically play when loaded.

Display
example

```
CD Auto Start
OFF
```

APS (automatic power saving) setting

Display
example

```
Menu
APS OFF
```

- When shipped new from the factory, the automatic power saving function is set to OFF in models for the US and Canada and ON in models for Europe.

OFF: The automatic power saving function is disabled.

ON: The automatic power saving function is enabled.

FA. Reset (restoring default settings)

Display
example

```
Factory Reset
OK?
```

When "OK?" appears, press the SELECT button to restore settings to their factory default values.

The unit will enter standby after settings are restored.

Message list

Operation messages

No Disc	No disc has been loaded.
Reading	A disc is being read.
EJECT	A disc is being ejected.

No Signal	The USB/OPTICAL input is not receiving an input signal.
Connected	The USB input is connected to a computer.
Fs: *** kHz	This shows the sampling frequency (Fs) of the track playing through the USB or OPTICAL input.
AUTO POWER SAVE	This appears 30 seconds before the automatic power saving function puts the unit into standby.

Error messages

Disc Error	The loaded disc has a scratch or other defect or it does not comply with standards.
Not Support	Playback of the loaded disc is not supported.
OVER LOAD	A problem occurred with speaker output. Turn off the power and check the connections.

Troubleshooting

General

The unit does not turn on.

(The power switch LED does not light.)

- ➔ Check that the power cord is completely plugged into the power outlet. If the outlet is switched, confirm that the switch is in the ON position.
- ➔ Connect a different electrical device to the outlet to confirm that it is supplying power.

Remote control does not work.

- ➔ Point the remote control at the front panel of the unit from a distance of less than about 5 m (16 ft).
- ➔ The remote control will not work if there is an obstruction between it and the main unit. In this case, try changing the position.
- ➔ If the batteries are exhausted, replace both of them with new ones.

A television set or another device operates in error.

- ➔ Some televisions that are able to receive signals from wireless remote controls might be operated in error by this unit's remote control. If this should occur, use the main unit's buttons.

No sound is output or very little sound is output.

- ➔ Confirm connections with the amplifier and speakers.
- ➔ Confirm connections with other devices.

There is noise.

- ➔ Place the unit as far away as possible from TVs, microwave ovens and other devices that have strong magnetism.

Radio

A station cannot be received. The reception is poor.

- ➔ Select a broadcast station.
- ➔ If reception is poor, try repositioning the antenna.
- ➔ If a TV is near the unit, turn the TV off.

Stereo broadcasts become mono.

- ➔ Press the remote control MODE button to select stereo.

CD Player

Playback is not possible.

- ➔ If the disc is upside down, reload it with the labeled side up.
- ➔ If the disc is dirty, wipe it clean.
- ➔ Depending on the quality and recording conditions of the disc, some CD-R/CD-RW discs cannot be played back.
- ➔ CD-R/CD-RW discs that have not been finalized cannot be played back.

The sound skips.

- ➔ Vibrations can cause the sound to skip. Install this unit in a stable location.
- ➔ If the disc is dirty, wipe it clean.
- ➔ Do not use discs that are scratched or cracked.

MP3 and WMA files

Playback is not possible.

- ➔ Check the file extension. Files are recognized by their extensions: "mp3" for MP3 files and "wma" for WMA files.
- ➔ The MP3/WMA file might be damaged.
- ➔ Check the file format. This unit can play MP3 and WAV files (page 38)

The names of tracks, artists and albums are not shown.

- ➔ There is no ID3 tag information for the music file. Use a computer, for example, to prepare MP3/WMA files with corrected ID3 tag information. ID3 tags cannot be used with WAV files.

Some characters are not shown correctly.

- ➔ If the file information uses Japanese, Chinese or other double-byte characters, playback is possible but the name will not be shown correctly.

Since this unit uses a microcontroller, external noise and other interference can cause the unit to malfunction. If this occurs, unplug the power cord, wait for a while, and then turn the power back on to restart operations.

Specifications

CD Player

Playback media	CD-DA, CD-R/RW
	Only 12cm discs can be used
Format	ISO9660 LEVEL 1/2/JOLIET
Maximum number of files	250 (including folders)
Maximum number of folders	99
Playable audio formats	
MP3	
Extension	“.mp3”, “.MP3”
Bit rate	32 kbps – 320 kbps or VBR
Sampling frequency	
16 kHz, 22.05 kHz, 24 kHz, 32 kHz, 44.1 kHz, 48 kHz	
Supported standards	MPEG-1/2 Audio Layer-3
WMA	
Extension	“.wma”, “.WMA”
Bit rate	32 kbps – 320 kbps or VBR
Sampling frequency	
8 kHz, 11.025 kHz, 16 kHz, 22.05 kHz, 32 kHz, 44.1 kHz, 48 kHz	
Supported standard	WMA ver.9

Digital audio input

Supported sampling frequencies (PCM)	
44.1 kHz, 48 kHz, 88.2 kHz, 96 kHz, 176.4 kHz, 192 kHz	
Supported bit depths	16/24

Bluetooth

Bluetooth version	3.0
Output	Class 2
Supported profile	A2DP
Codecs	SBC, AAC, aptX

Headphones output

Rated output	80 mW + 80mW (32 Ω, 1 kHz)
Total harmonic distortion	0.03%

Tuner

Frequency range	
FM	87.5 MHz to 108.0 MHz

Amplifier Section

Maximum output	26 W + 26 W (JEITA 10%, 1 kHz, 4 Ω)
Rated output	20 W + 20 W (JEITA 1%, 1 kHz, 4 Ω)
Total harmonic distortion	0.08% (1 kHz, 4 Ω, 1 W)
Signal-to-noise ratio	
LINE IN	90 dB (IHF-A/LPF 20kHz/1kHz, 2V input)
Frequency Response	20 Hz – 45 kHz (–5 dB)

General

Power supply	
Model for Europe	AC 220–240 V (50 Hz)
Model for USA/Canada	AC 120 V (60 Hz)
Power consumption	21 W
External dimensions	
182 × 93 × 221 mm (7 1/4" × 3 3/4" × 8 3/4")	
(W × H × D, including protrusions)	
Weight	2.2kg (4 7/8 lb)
Operating temperature	+5°C to +35°C
Operating humidity	5% to 85% (no condensation)
Storage temperature	–20°C to +55°C

Included accessories

Power cord	× 1
Remote control (RC-1324)	× 1
Batteries for remote control (AAA)	× 2
Basic FM antenna	× 1
Owner's manual	× 1
Warranty card	× 1 (for users in the USA and Canada only)

- In order to improve the product, specifications and appearance could be changed at any time without warning.
- Weight and dimensions are approximate.
- Illustrations in this manual might differ in part from the actual product.

WARRANTY/GARANTIE/GARANTÍA/GARANTIE/GARANZIA/ GARANTIE/GARANTI

Europe/Europa

This product is subject to the legal warranty regulations of the country of purchase. In case of a defect or a problem, please contact the dealer where you bought the product.

Ce produit est sujet aux réglementations concernant la garantie légale dans le pays d'achat. En cas de défaut ou de problème, veuillez contacter le revendeur chez qui vous avez acheté le produit.

Las condiciones de garantía de este aparato están sujetas a las disposiciones legales sobre garantía del país en el que ha sido adquirido. En caso de garantía, debe dirigirse al establecimiento donde adquirió el aparato.

Dieses Gerät unterliegt den gesetzlichen Gewährleistungsbestimmungen des Landes, in dem es erworben wurde. Bitte wenden Sie sich im Gewährleistungsfall an den Händler, bei dem sie das Gerät erworben haben.

Questo apparecchio è conforme alle norme sulla garanzia vigenti nel rispettivo Paese in cui esso è stato acquistato. Si prega di rivolgersi al proprio commerciante, presso il quale è stato acquistato l'apparecchio, nel caso in cui si voglia richiedere una prestazione in garanzia.

Dit product valt onder de wettelijke garantievoorschriften van het land waar het is aangeschaft. Neem bij een defect of probleem contact op met de leverancier waar u het product heeft gekocht.

För denna produkt gäller det lagliga garantiregleringar av landet där köpet gjordes. Vid fel eller problem kontakta vänligen återförsäljaren, där du köpte produkten.

In countries/regions other than the USA, Canada and Europe

This warranty gives you specific legal rights, and you may also have other rights that vary by country, state or province.

If you have a warranty claim or request, please contact the dealer where you bought the product.

该保证书赋予了顾客特定的合法权利，并且因国家、州或省等地域的不同，顾客可能拥有其他权利。如需申请或要求保修，请与购买本产品的销售店进行联系。

TEAC

TEAC CORPORATION 1-47 Ochiai, Tama-shi, Tokyo 206-8530, Japan Phone: +81-42-356-9156

TEAC AMERICA, INC. 1834 Gage Road, Montebello, California 90640 U.S.A. Phone: +1-323-726-0303

TEAC AUDIO EUROPE Gutenbergstr. 3, 82178 Puchheim, Germany Phone: +49-8142-4208-141

This device has a serial number located on its back panel. Please record the serial number and retain it for your records.

Model name: CR-H101

Serial number

0116 MA-2239B
