

ADVANCE
PARIS

A8 | APEX

30TH EDITION

USER MANUAL

version 3 - mars 2026

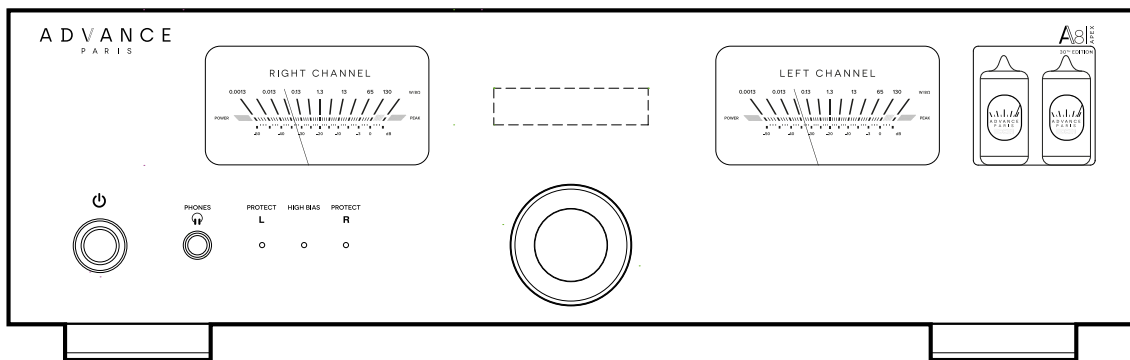

ENGLISH

USER'S MANUAL

The Advance Paris team would like to thank you for choosing an A8 APEX amplifier.

To take full advantage of its performance and ensure optimal operation, please read this user manual carefully before using your amplifier for the first time.

Once you have finished reading it, we recommend that you keep this manual for future reference. This user manual also can be found on the A8 APEX product page on the Advance Paris website.

Table of Contents

Contents

Accessories	5
-------------------	---

Description

Front panel	7
Rear panel	8
Remote control	9

Connections

Speaker connection	11-12
Subwoofer connection	13
Connecting a TV	14
Home cinema system	15
Connecting a turntable	16
Connecting a source	17
Connecting a computer	18
Bluetooth connection	19
Connecting a recording device	20
Connecting a wired headset	21
Connecting an external amplifier	22
Switch on a product at the same time as your amplifier	23
Connecting the power cord	24

Usage

Switch on	26
Wake from Standby	27
Selecting the input	28
Volume adjustment	29
Muting	30
Using a device connected to the A-BTC	31
Using your TV as an audio source	32
Using your APEX as a power amplifier	33
Using your turntable	34

Settings

How to access the settings menu with the remote control	36
How to access the settings menu using the multifunction control	37
Subwoofer output configuration	38
Adjusting the brightness	39
Setting the automatic standby mode	40
Tone and balance adjustment	41
Loudness adjustment	42
Volume adjustment at start-up	43
Deactivating the Standby button light	44
Disable HDMI CEC control	45
High-Bias Setting	46
Reset	47

Update / Frequently Asked Questions

Internal software information	49
Update	50
Frequently asked questions	51

Appendices

Glossary	53-54
Dimensions/Weight	55
Specifications	56



CONTENTS

DESCRIPTION

CONNECTIONS

USAGE

SETTINGS

FAQ

APPENDICES

Accessories

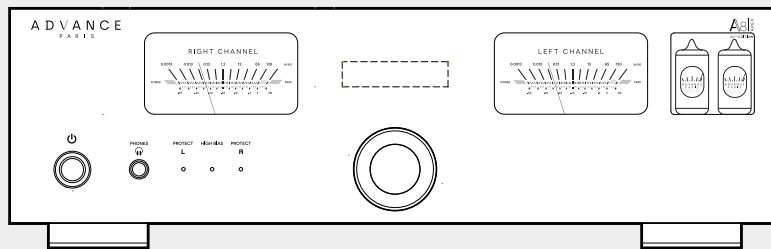

A8 APEX

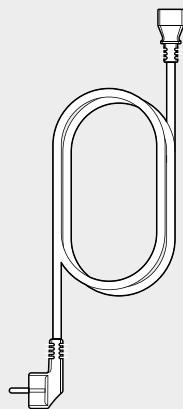

Power cord

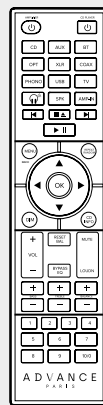

Remote control
REM-19

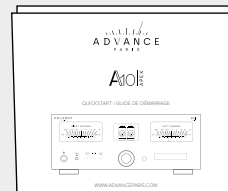

Quickstart



Safety instructions





CONTENTS	DESCRIPTION	CONNECTIONS	USAGE	SETTINGS	FAQ	APPENDICES
----------	--------------------	-------------	-------	----------	-----	------------

Front panel7
Rear panel8
Remote control9



Front panel



Always install your hi-fi system with the devices disconnected from the mains.

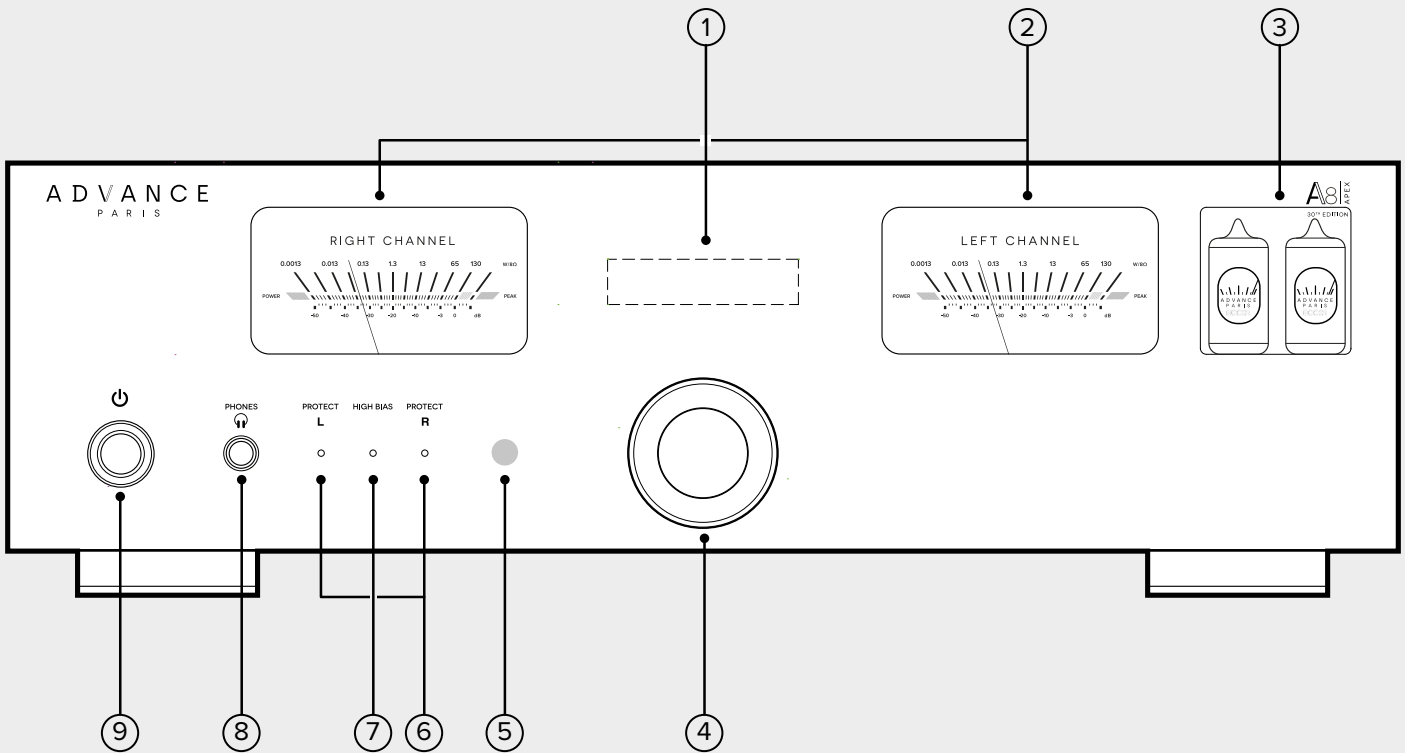

By pressing and holding the Multifunction control for more than one second, you can access the various settings menus for your APEX amplifier.

By turning the multifunction control, you can scroll through the various entries in the settings menu.

To access a specific setting, you must briefly press the Multifunction control.

To return to the previous level, you must press and hold the multifunction control.

- ① Screen
- ② VU meter
- ③ Tubes
- ④ Multifunction control (Volume / Input selection / Adjustment)
- ⑤ Infrared Receiver
- ⑥ Protection diodes (Protect L et Protect R)
- ⑦ High-Bias
- ⑧ 6.35 mm headphone jack
- ⑨ Standby button

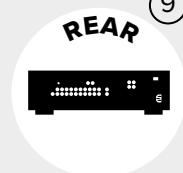



Rear panel

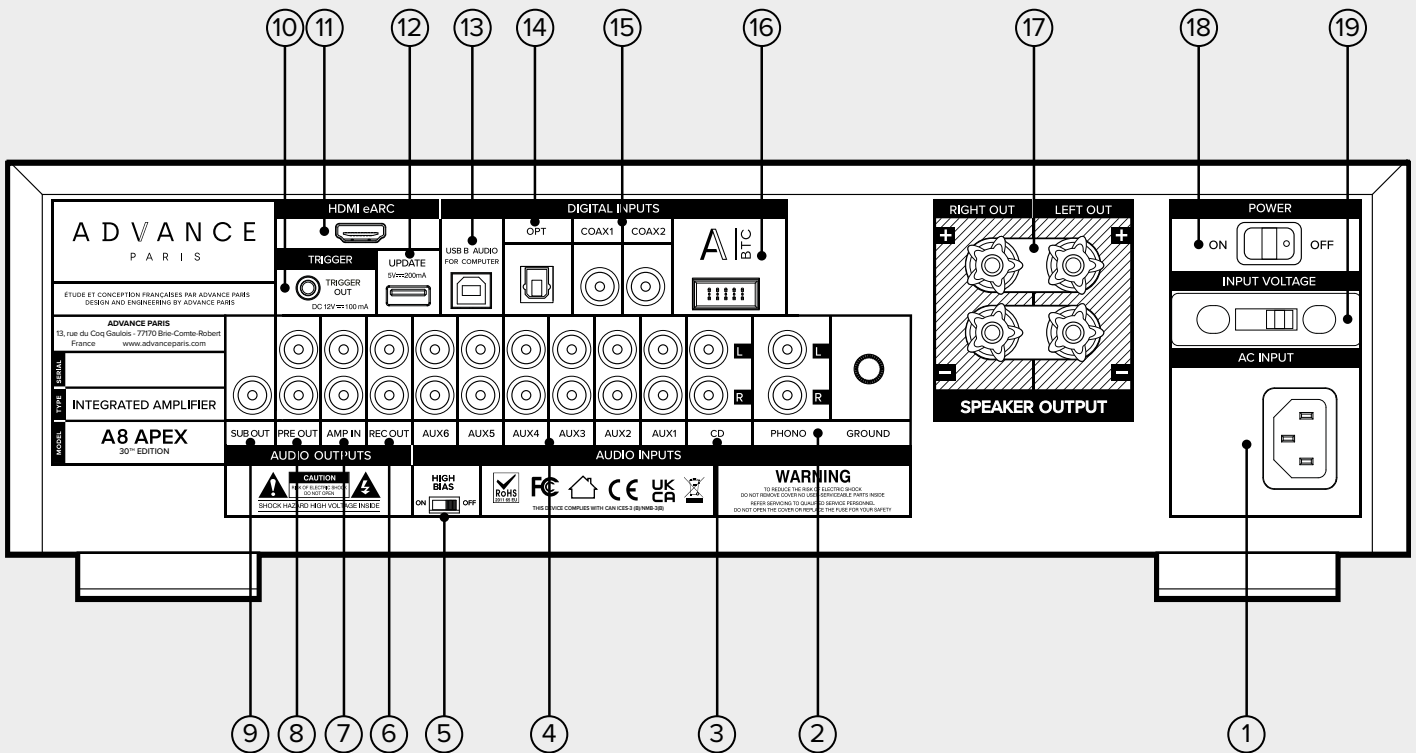

- ① Mains socket
- ② MM phono input with ground
- ③ CD input
- ④ AUX inputs (X6)
- ⑤ High Bias
- ⑥ AMP-IN input
- ⑦ REC OUT output
- ⑧ Preamplifier Out
- ⑨ Subwoofer output
- ⑩ Trigger OUT
- ⑪ HDMI eARC
- ⑫ USB Update ONLY
- ⑬ USB port for computer
- ⑭ Optical digital input
- ⑮ Coaxial digital input (X2)
- ⑯ A-BTC Connection
- ⑰ Loudspeaker Terminal
- ⑱ Mains switch
- ⑲ Voltage selection (115–230V)

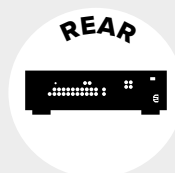



Remote control



To avoid damaging the remote control or battery leakage:

- Do not mix new and used batteries or different types of batteries.
- Remove the batteries during prolonged periods of non-use.
- In the event of a leak, clean the compartment before replacing the batteries.

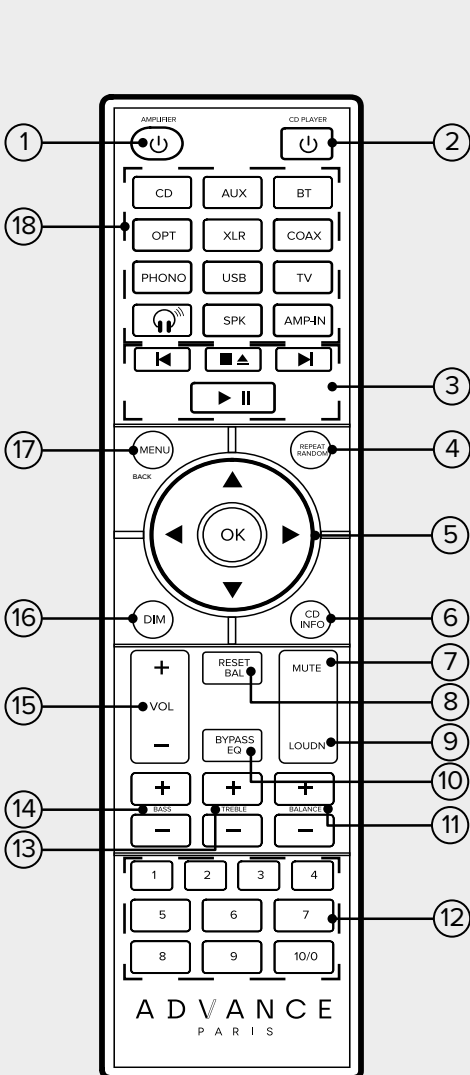

- ① Switch on/Switch off
- ⑤ OK = select
Arrows = next/previous
- ⑦ Mute
- ⑧ Balance Reset
- ⑨ Loudness
- ⑩ EQ deactivation
- ⑪ Balance adjustment
- ⑬ Treble adjustment
- ⑭ Bass adjustment
- ⑮ Volume control
- ⑯ Brightness adjustment
- ⑰ Menu
- ⑱ Sources selection

The buttons in the areas

- ② ③ ④ ⑥ ⑫

are specific to
ACD APEX CD player

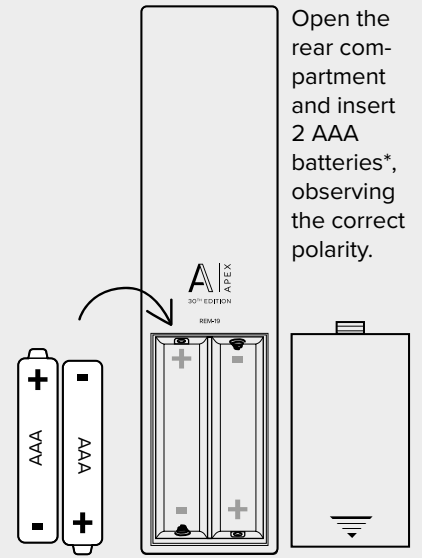

*batteries not included

Approximately 6m, angle of 30 degrees on each side, the IR receiver is located halfway between the volume button and the display.

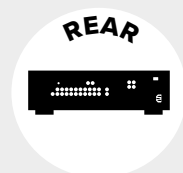
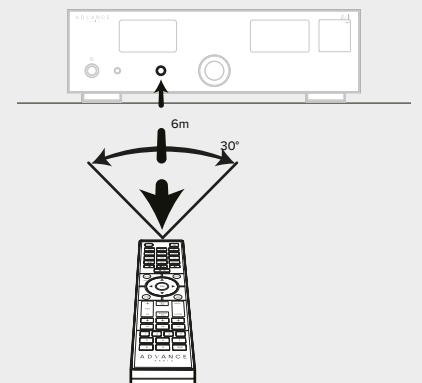



EN

CONTENTS

DESCRIPTION

CONNECTIONS

USAGE

SETTINGS

FAQ

APPENDICES

Check that the operating voltage is correctly set on the rear panel of your amplifier and corresponds to the voltage in your country.

Please connect all your sources **BEFORE** connecting the amplifier to the mains.



Connecting sources while your amplifier is switched on may expose your speakers to loud noise and cause your speakers to fail.

Speakers11-12
Subwoofer13
Television14
Home cinema15
Turntable16
Sources17
Computer18
Bluetooth19
Recording device20
Wired headset21
External amplifier22
Simultaneous Switch On23
Power cord24





CONTENTS

DESCRIPTION

CONNECTIONS

USAGE

SETTINGS

FAQ

APPENDICES

Speakers

Cable preparation

The terminals on your APEX amplifier are compatible with bare cables, spades and banana plugs.

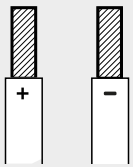

To connect your **bare cables**, you must remove 1 cm of the cable sheath. Unscrew the terminal blocks until the holes in the terminal block axis appear. Insert the bare cable and check that the copper strands do not come into contact with the neighbouring terminal block.

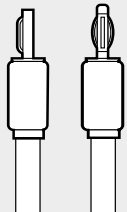

To connect your **cables with banana plugs**, you must remove the red and black blanking covers in the centre of the terminals. Then insert your various speaker cables, observing the polarity (red + and black -) and the sides (left and right).

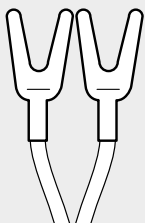

To connect your **cables with spade terminals**, unscrew each terminal block and insert the spade terminals. Then screw the terminal blocks back on, ensuring that the spade terminals do not touch each other.





CONTENTS

DESCRIPTION

CONNECTIONS

USAGE

SETTINGS

FAQ

APPENDICES

Speakers

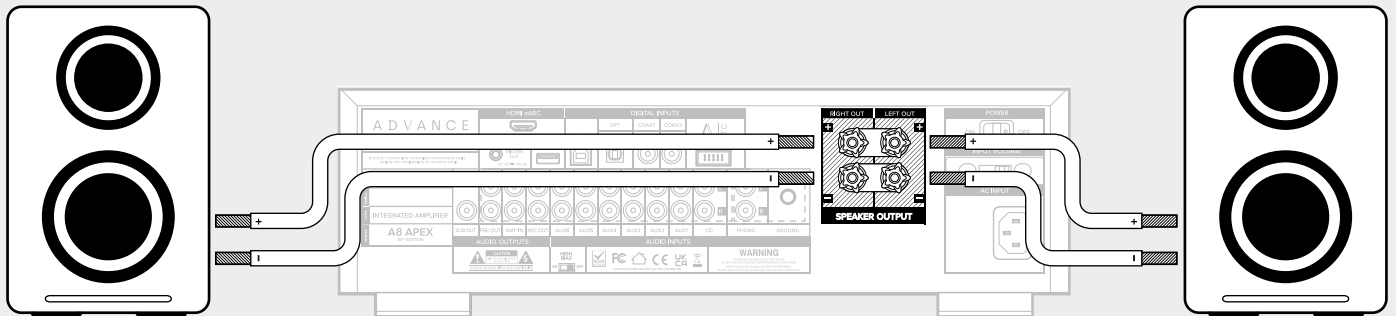

See "Settings" for speaker output configuration.





EN

CONTENTS

DESCRIPTION

CONNECTIONS

USAGE

SETTINGS

FAQ

APPENDICES

Subwoofer

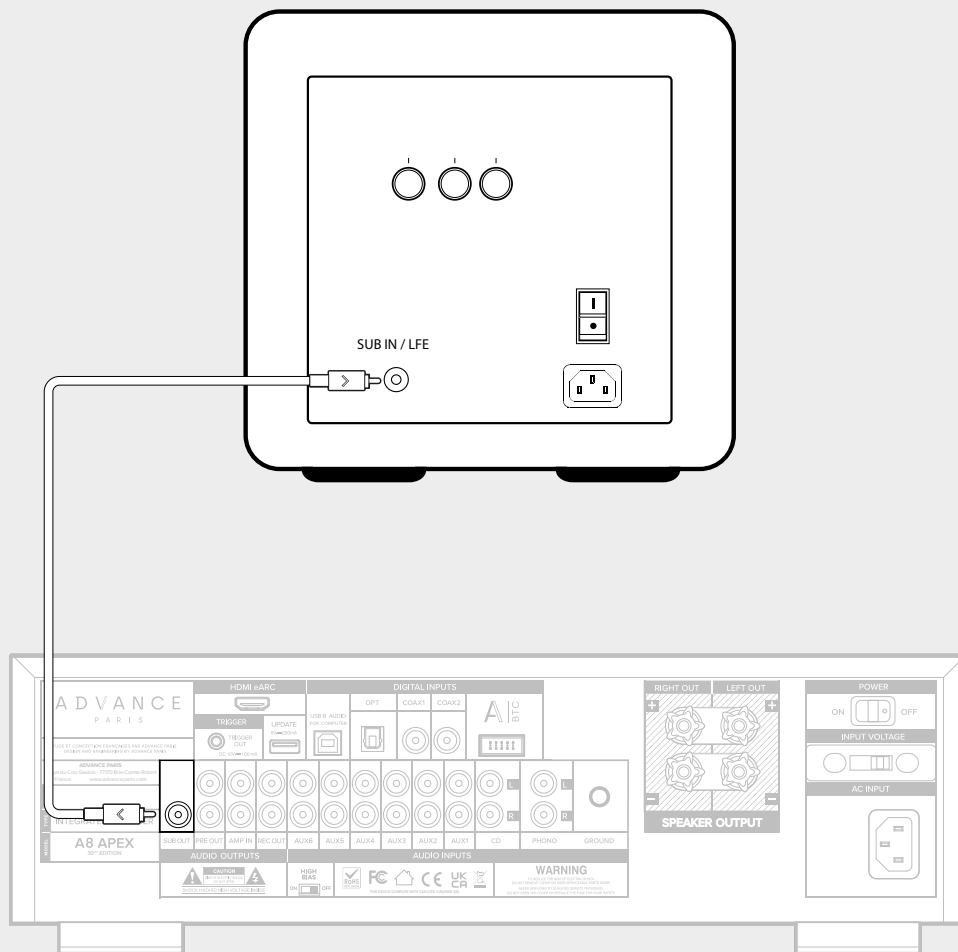

See «Settings» for configuring the subwoofer outputs.

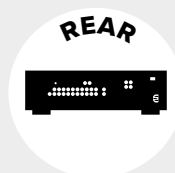

Television

HDMI eARC socket

Your APEX amplifier significantly enhances your TV sound experience by allowing you to use your speakers rather than your television's built-in speakers when watching television.

To enjoy this feature, simply connect an HDMI cable between your APEX amplifier and the HDMI ARC (or eARC) socket on your television.

You can also use your television remote only control to control the power, standby and volume of the APEX amplifier.

NOTE: Your APEX amplifier is only compatible with stereo signals (not multi-channel).

NOTE: If you change the input from HDMI on your APEX amplifier, it will no longer respond to commands sent by the television.

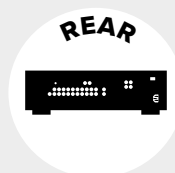
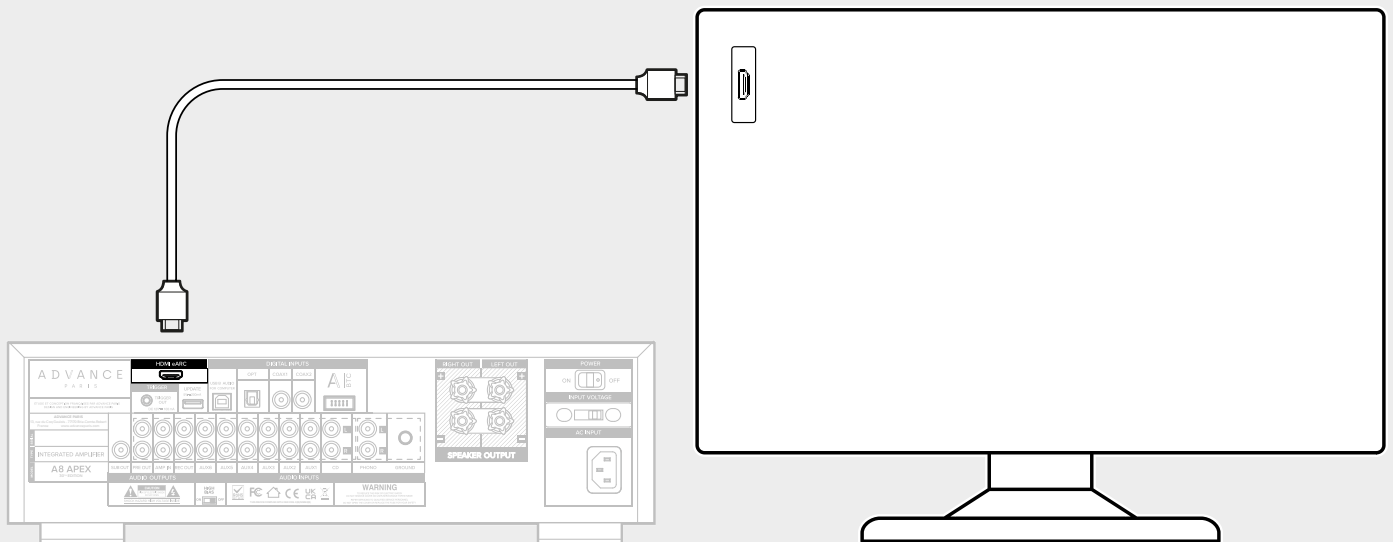



EN

CONTENTS	DESCRIPTION	CONNECTIONS	USAGE	SETTINGS	FAQ	APPENDICES
----------	-------------	-------------	-------	----------	-----	------------

Home cinema

AMP-IN socket

To use your APEX amplifier as a power amplifier with your home cinema amplifier, connect them using the AMP-IN sockets on the rear panel. This connection allows the home cinema system to control the amplification of the front speakers, while benefiting from the audio quality of your APEX amplifier.

Connect the front PRE-OUT outputs (Front L/R) of your home cinema amplifier to the AMP-IN inputs of the APEX amplifier using an RCA cable.

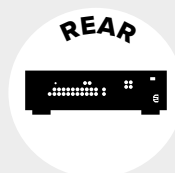
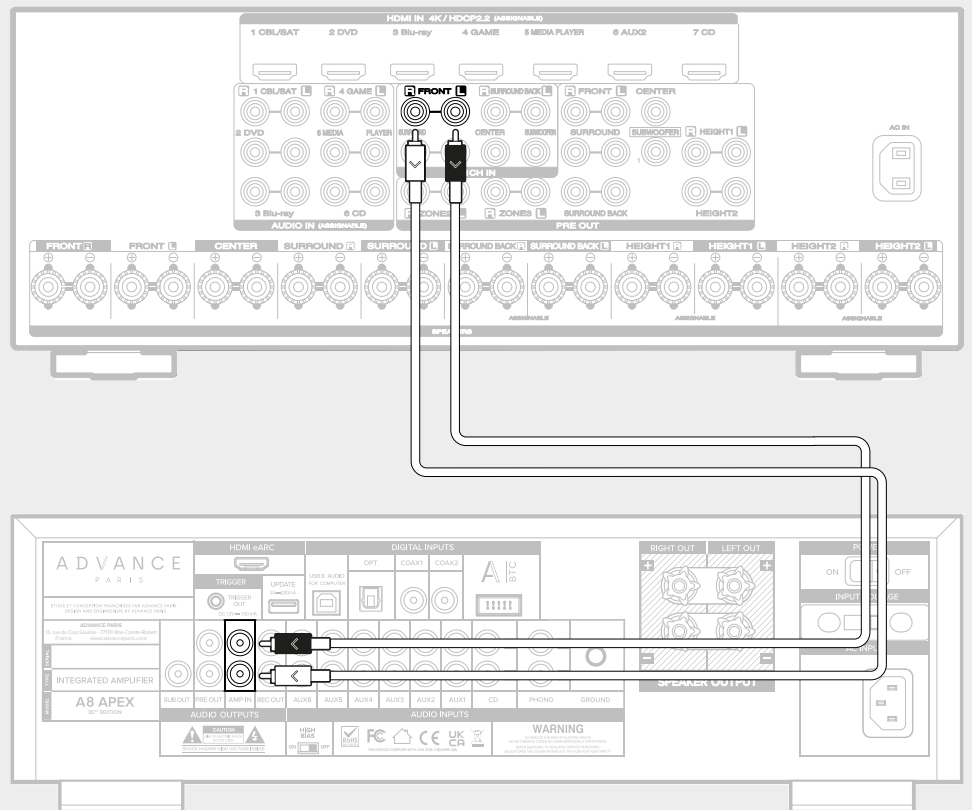

Turntable

Phono socket

To get the most out of your turntable, connect it directly to the phono input on your APEX amplifier. This input is specially designed for **moving magnet (MM) cartridges** and incorporates the RIAA preamplifier required for correct playback of vinyl records.

NOTE: It is important to make connections with the APEX amplifier switched to OFF. Connecting sources while your amplifier is switched on may expose your speakers to loud noise and cause your speakers to fail.

Also connect the ground cable from your turntable to eliminate any humming noises.

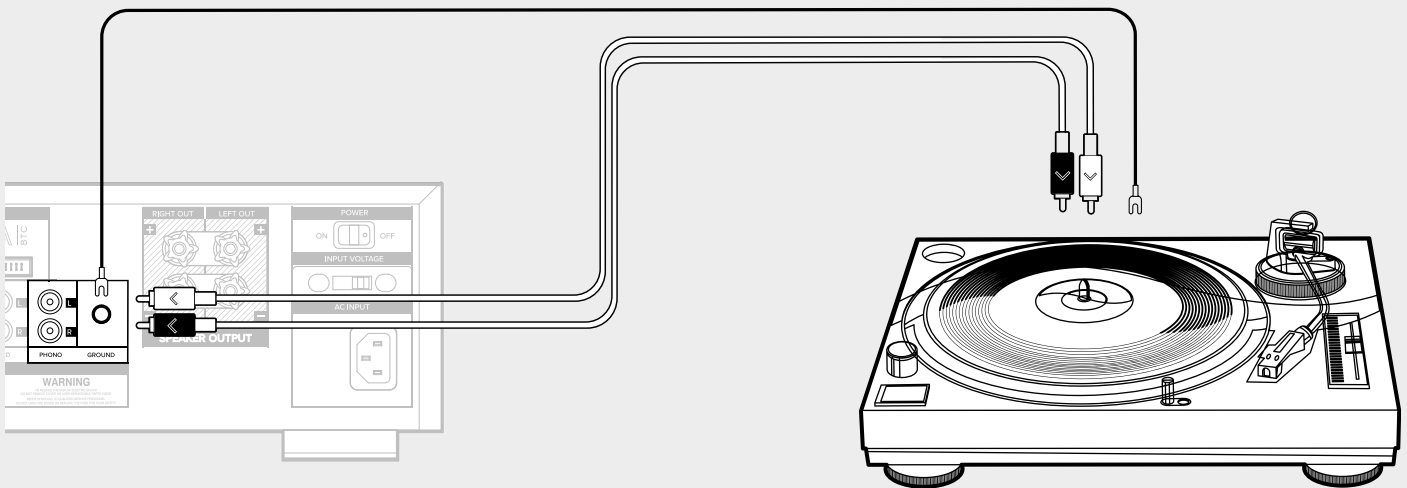

See «Settings» for the capacitance setting of the MM phono input.





EN

CONTENTS	DESCRIPTION	CONNECTIONS	USAGE	SETTINGS	FAQ	APPENDICES
----------	-------------	--------------------	-------	----------	-----	------------

Sources



CAUTION: Do not connect any source to the AMP-IN input. Doing so may result in high sound levels from your speakers and possible failure.

ANALOGUE INPUT

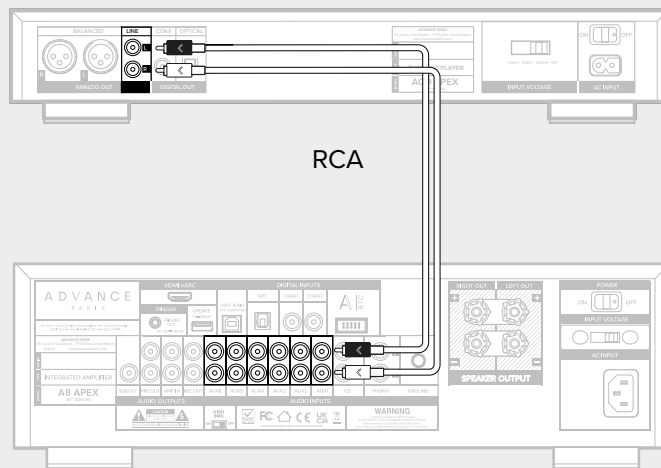

DIGITAL INPUTS

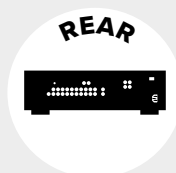
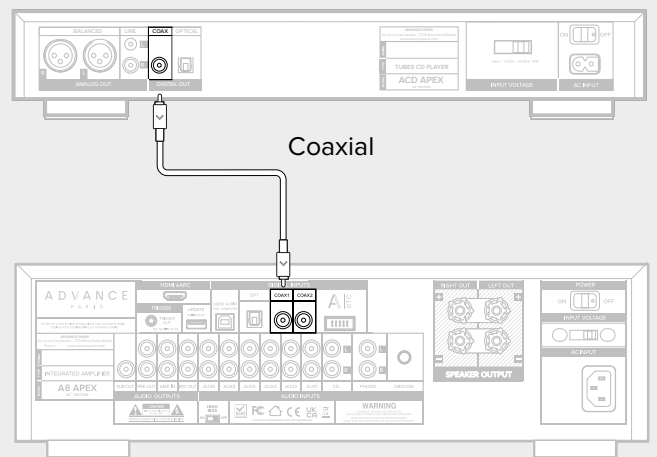
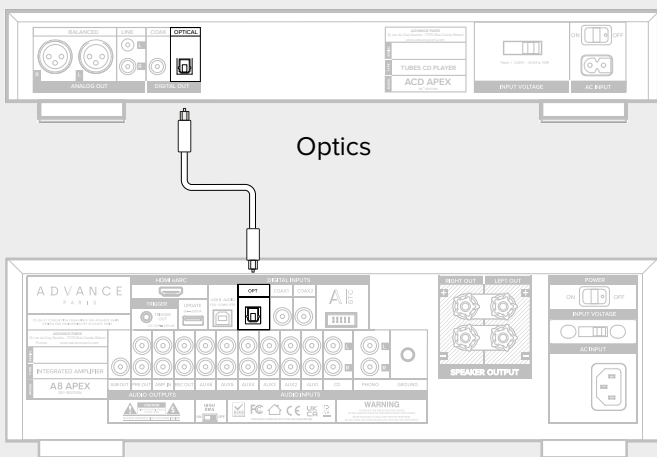



EN

CONTENTS	DESCRIPTION	CONNECTIONS	USAGE	SETTINGS	FAQ	APPENDICES
----------	-------------	-------------	-------	----------	-----	------------

Computer

USB Type B input

Compatible with Apple OS and Windows 10-11 without the need to install drivers on your computer. USB 2.0 specification up to 24-bit/192kHz. Compatible with DSD 64, 128 and 256.

Select the Advance Paris audio output on your computer in the sound card settings.

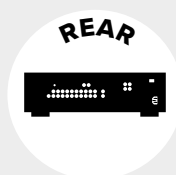
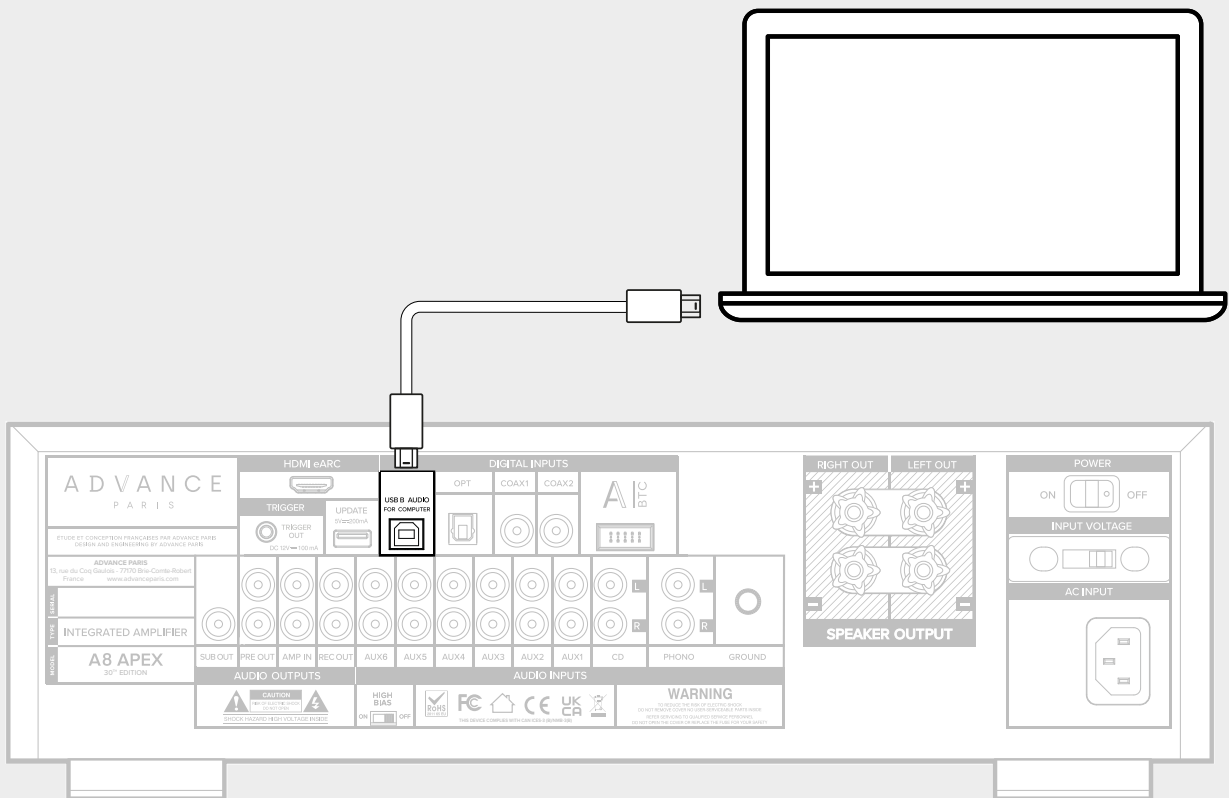



EN

CONTENTS	DESCRIPTION	CONNECTIONS	USAGE	SETTINGS	FAQ	APPENDICES
----------	-------------	-------------	-------	----------	-----	------------

Bluetooth

A-BTC audio input

To connect a Bluetooth source to your APEX amplifier, you will need the Advance Paris A-BTC product (optional). The A-BTC must be inserted into the specific socket located on the rear panel of your APEX amplifier (the APEX amplifier must be switched OFF at its mains switch).

NOTE : It is not possible to connect a Bluetooth headphone on the A8 APEX through the A-BTC.

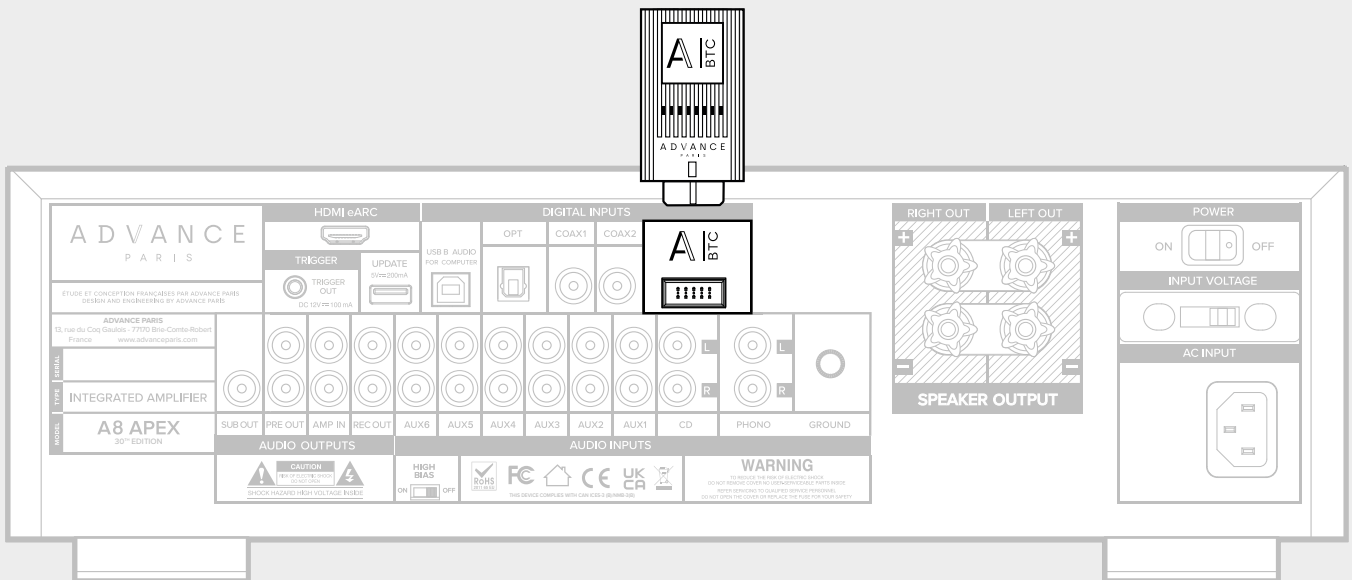

See «Usage» for more details.

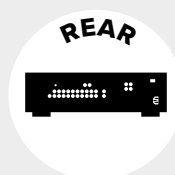



Recording device

REC-OUT socket

You can connect a recorder to the REC-OUT socket.

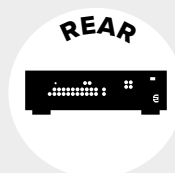
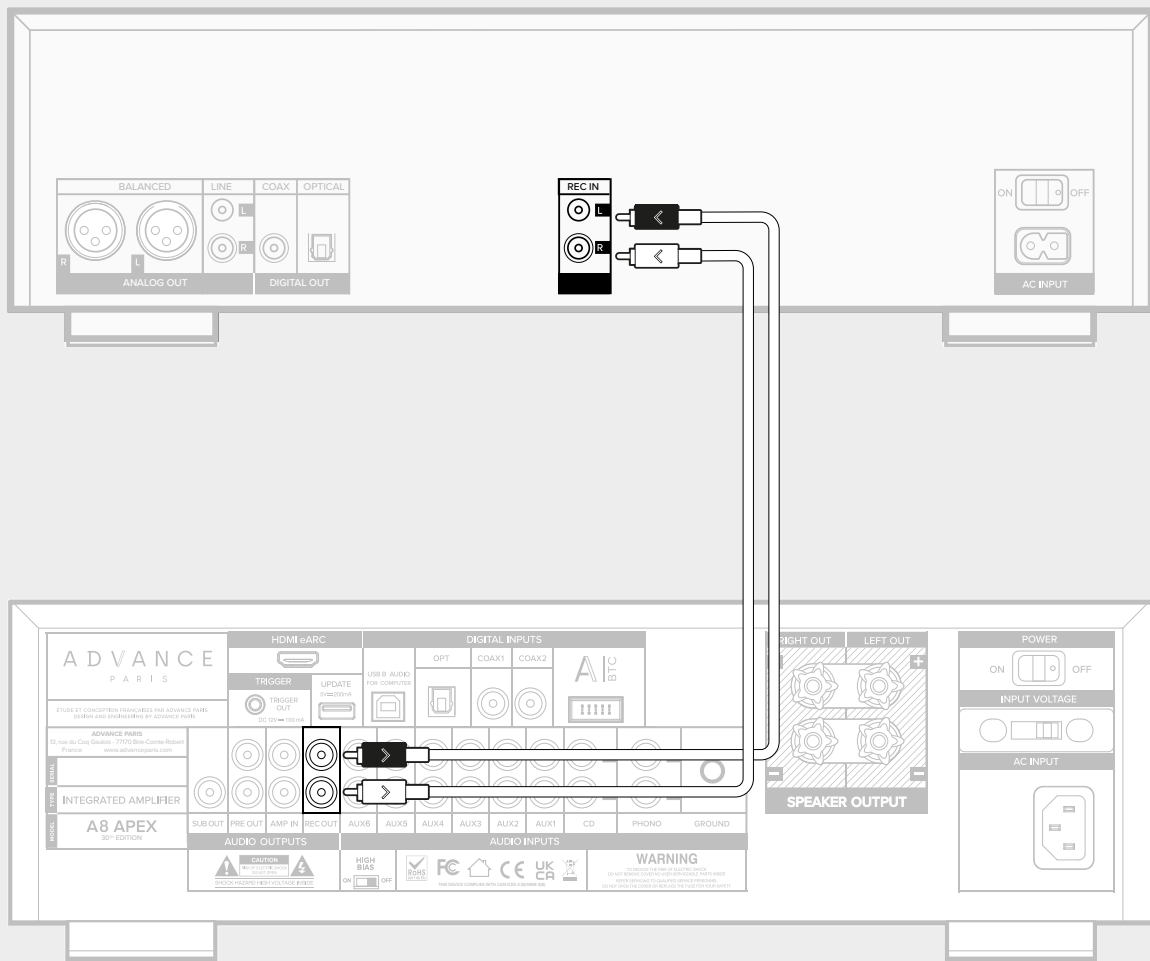



EN

CONTENTS

DESCRIPTION

CONNECTIONS

USAGE

SETTINGS

FAQ

APPENDICES

Wired headset

Connect your wired headphones to the 6.35mm jack on the front of the APEX amplifier.

The speaker outputs are muted when headphones are plugged into the front panel.

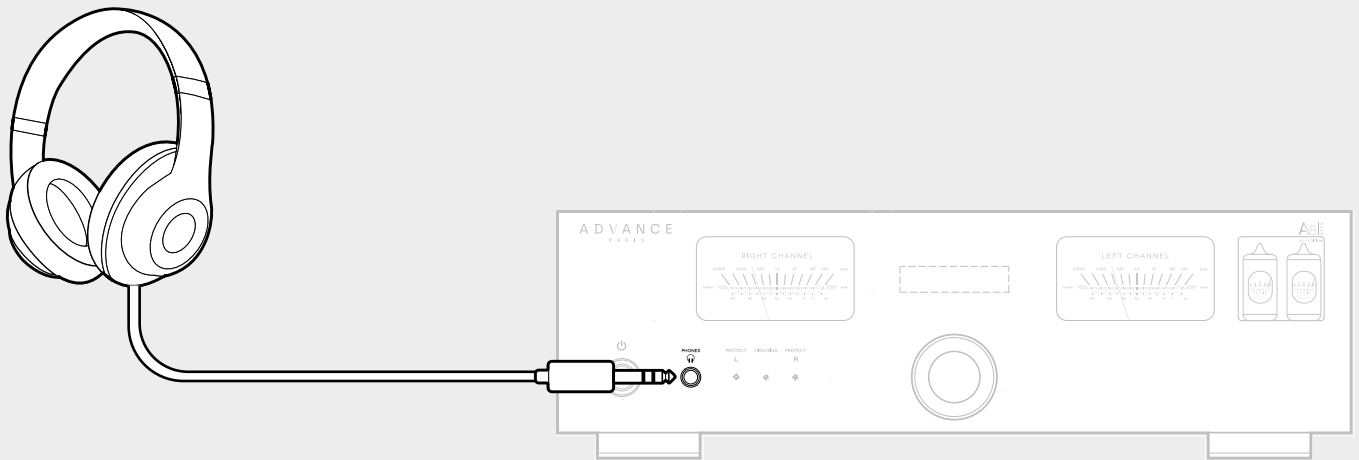



EN

CONTENTS

DESCRIPTION

CONNECTIONS

USAGE

SETTINGS

FAQ

APPENDICES

External amplifier

PRE-OUT socket

You can connect a mono or stereo power amplifier to your APEX amplifier. This can give you more power and better audio quality depending on your speakers.

You must connect the PRE-OUT outputs of your APEX amplifier to the inputs of your power amplifier using an RCA cable.

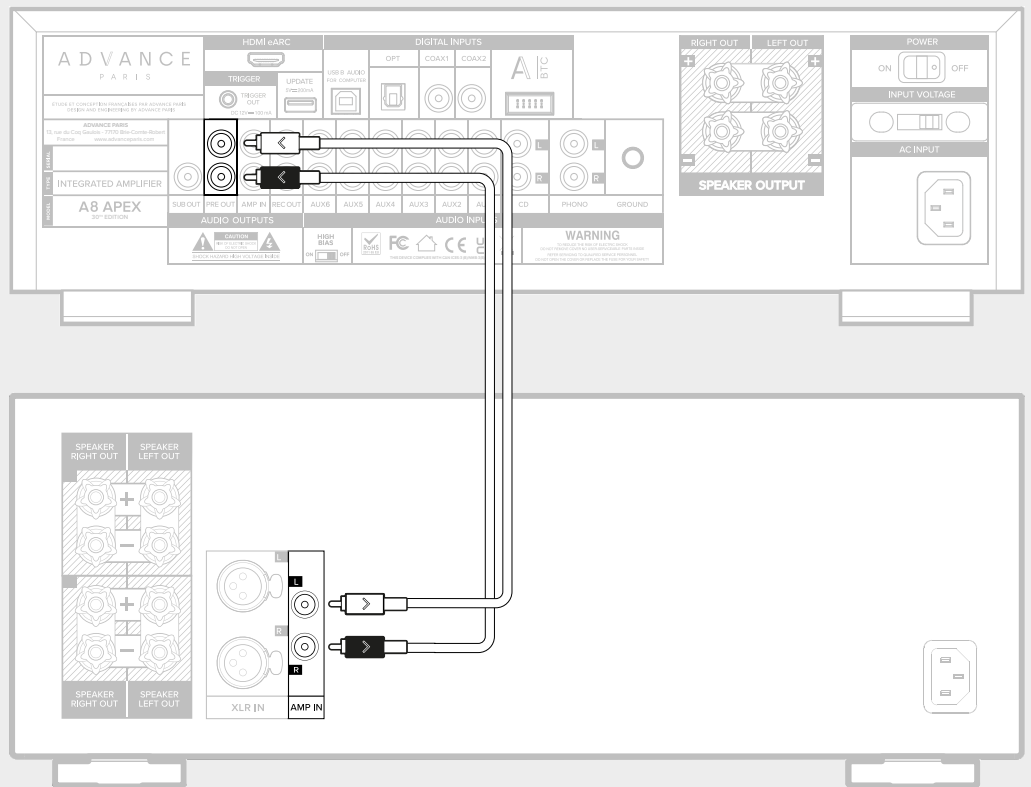

NOTE: Your speakers will be connected to your external power block (not to your APEX amplifier).

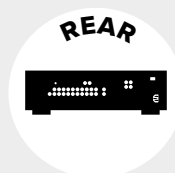



EN

CONTENTS	DESCRIPTION	CONNECTIONS	USAGE	SETTINGS	FAQ	APPENDICES
----------	-------------	-------------	-------	----------	-----	------------

Simultaneous Switch On

Trigger OUT socket

You can activate a third-party product when switching on your APEX amplifier. To do this, your third-party product must be equipped with a Trigger IN socket.

Connect a 3.5mm mono cable (not supplied) between the Trigger OUT socket on the APEX amplifier and the Trigger IN socket on your third-party product.

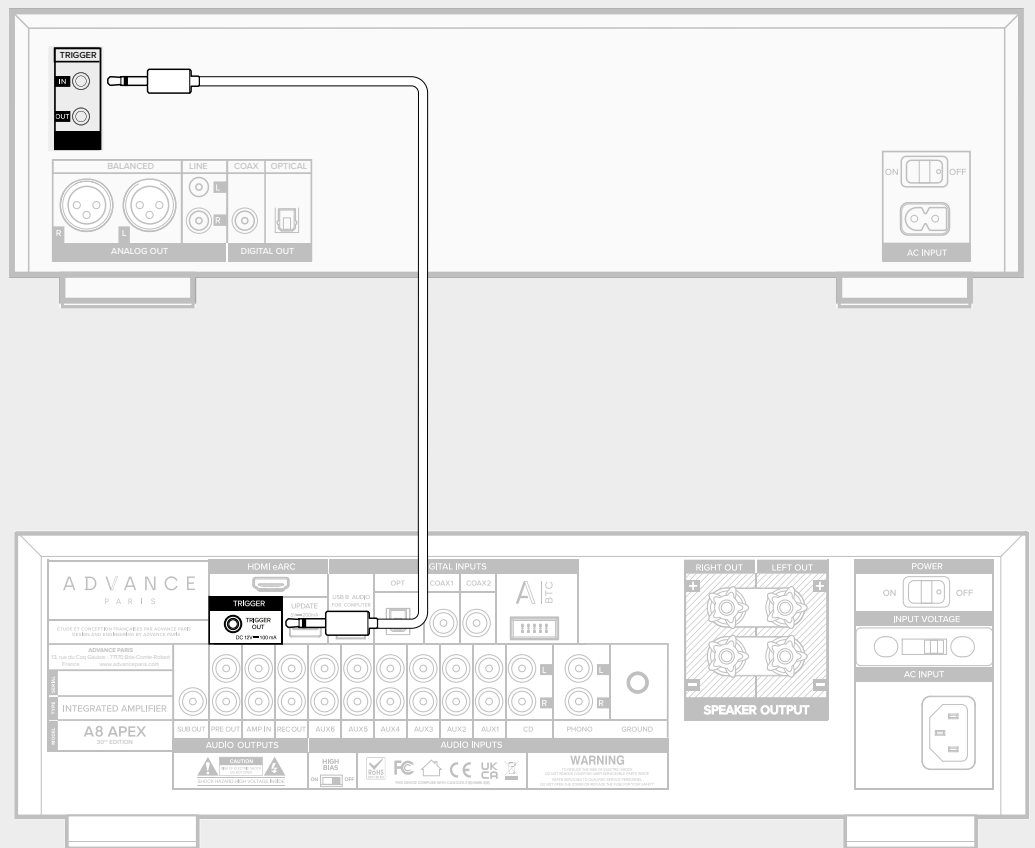

Power cord

NOTE: It is important to check the voltage setting (1) before connecting the power cord (2). Failing to do so and sending the wrong voltage to the amplifier might destroy your APEX amplifier. BEWARE !

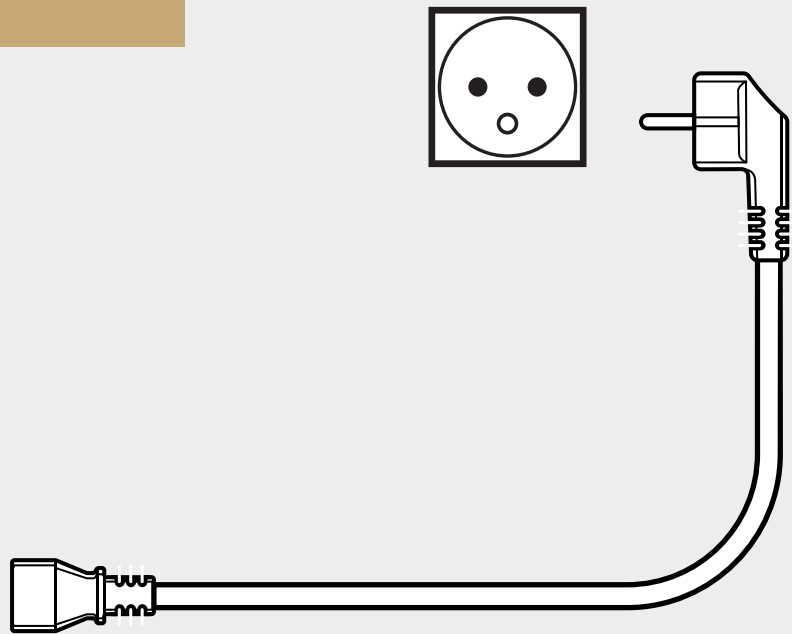
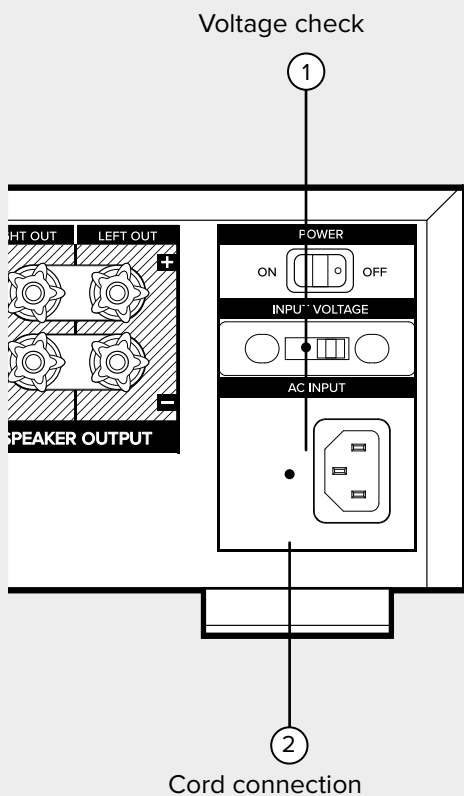



EN

CONTENTS	DESCRIPTION	CONNECTIONS	USAGE	SETTINGS	FAQ	APPENDICES
----------	-------------	-------------	--------------	----------	-----	------------

Switch on26
Wake from Standby27
Selecting the input28
Volume adjustment29
Muting30
Connecting devices in Bluetooth with the A-BTC31
Television as an audio source32
APEX amplifier as power amplifier33
Using your turntable34





EN

CONTENTS

DESCRIPTION

CONNECTIONS

USAGE

SETTINGS

FAQ

APPENDICES

Switch on

Switch at the rear

To use your APEX amplifier, you must set the mains switch on the rear panel to ON.

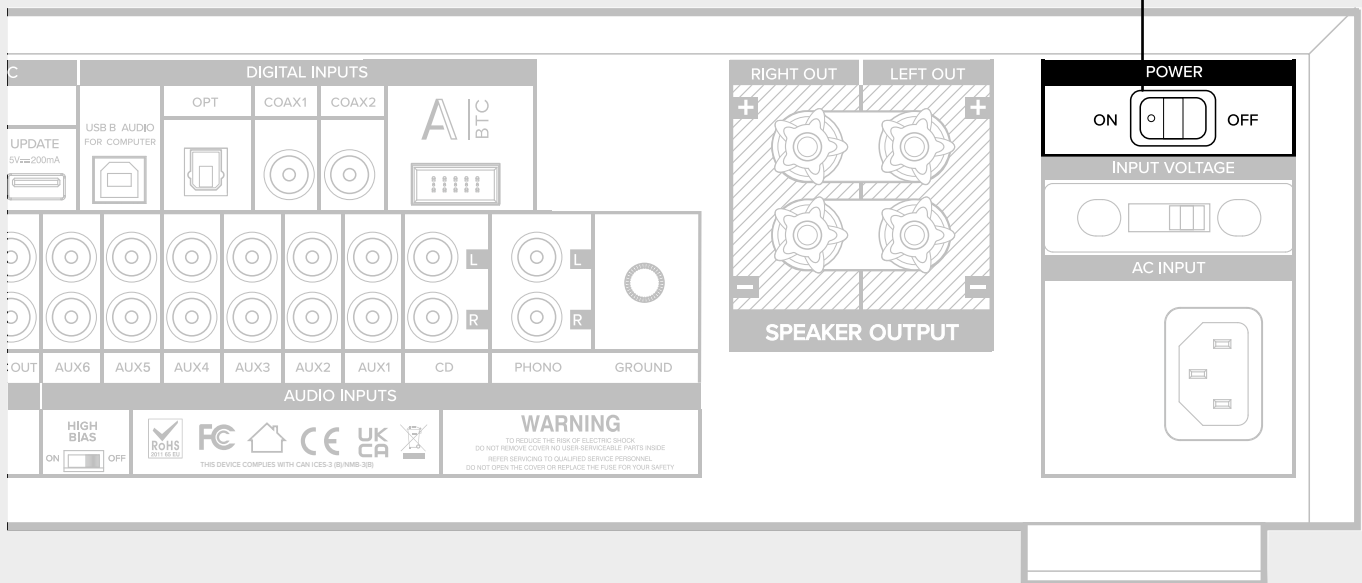



CONTENTS	DESCRIPTION	CONNECTIONS	USAGE	SETTINGS	FAQ	APPENDICES
----------	-------------	-------------	--------------	----------	-----	------------

Wake from Standby

Front panel button or remote control

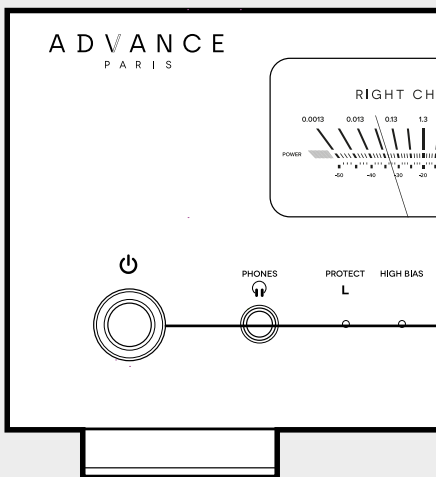

To switch on your APEX amplifier, use the remote control and its standby button or the standby button on the front panel of the APEX amplifier.



Your APEX amplifier has audio valves. A 30-second warm-up period is required. During this time, your amplifier will not emit any sound.

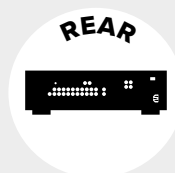



EN

CONTENTS

DESCRIPTION

CONNECTIONS

USAGE

SETTINGS

FAQ

APPENDICES

Selecting the input

Use your Remote control handset or multifunction button on the front panel

Your APEX amplifier has numerous inputs on its rear panel.



• Once your sources are connected, you can select them using the remote control.

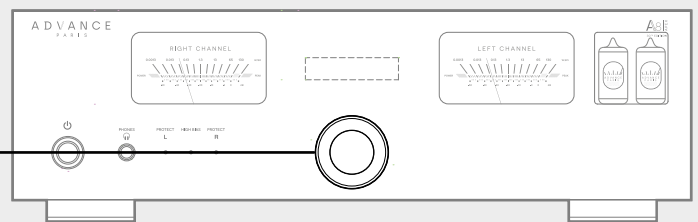

You may also use the multifunction control.
A long press will display a selection of analogue inputs, digital, Bluetooth, HDMI ARC (television), USB audio.
Turn the multifunction knob and select by briefly pressing the multifunction button.

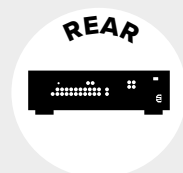



Volume control

Front panel control or remote control handset

You can change the volume by turning the multifunction control on the front panel of your APEX amplifier. Turn clockwise to increase the volume. Turn anticlockwise to decrease the volume.

You can change the volume using the «Vol +» and «Vol -» buttons directly from the remote control. By holding down these buttons, you can quickly increase the volume.

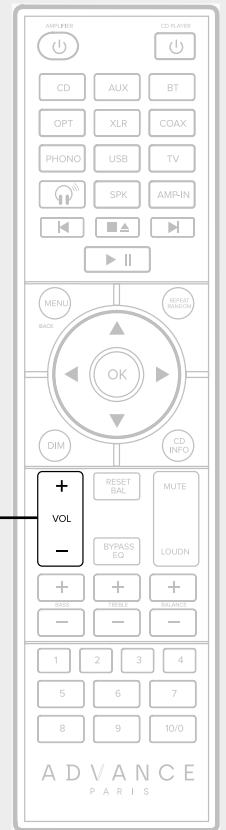
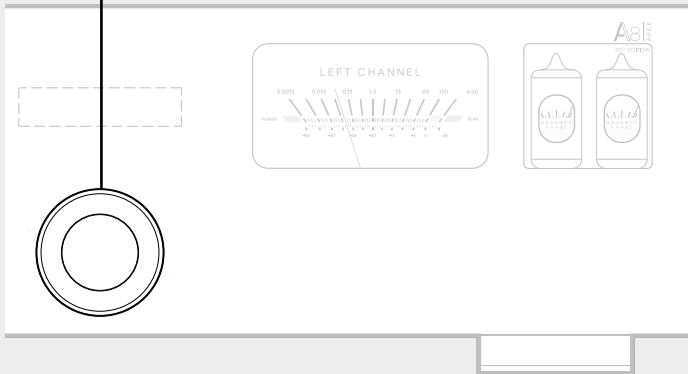



EN

CONTENTS

DESCRIPTION

CONNECTIONS

USAGE

SETTINGS

FAQ

APPENDICES

Muting

Remote control

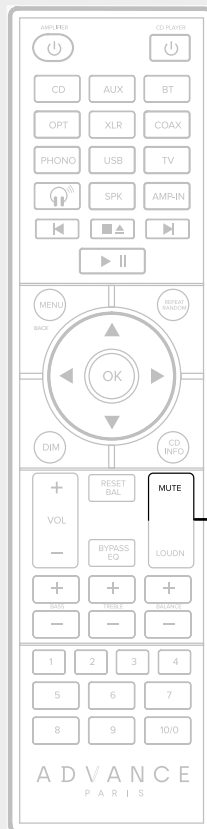

By pressing the «MUTE» button on the remote control, you can mute the sound completely.

Pressing the «MUTE» button again will return the sound to its original level. You can also press the «Vol +» or «Vol -» buttons to deactivate the «MUTE» function.





CONTENTS

DESCRIPTION

CONNECTIONS

USAGE

SETTINGS

FAQ

APPENDICES

Devices connected via Bluetooth to the A-BTC

Switch ON your APEX amplifier and select the Bluetooth input. You must go to the Bluetooth settings on your Bluetooth source (phone, tablet, computer) and select A-BTC.

You can now send music to your APEX amplifier. Check the volume on your Bluetooth source and on your amplifier.

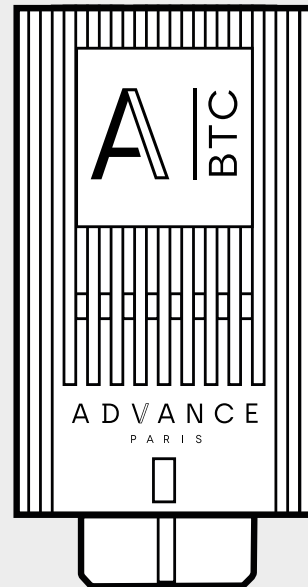



Television as an audio source

Front panel control or remote control handset

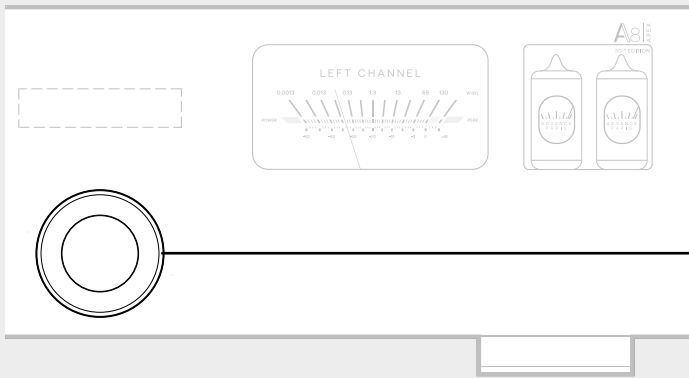

Once the HDMI cable is connected between your APEX amplifier and the television, you can select the TV input using the remote control or via the APEX amplifier settings menu (HDMI ARC input).

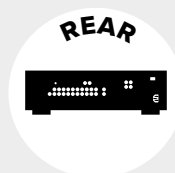



EN

CONTENTS

DESCRIPTION

CONNECTIONS

USAGE

SETTINGS

FAQ

APPENDICES

APEX as a power amplifier

Select the AMP-IN input on your stereo amplifier using the remote control.

Your home cinema amplifier will now manage the volume and sound balance of the front speakers during home cinema sessions.

Your installation is now complete. You can now enjoy the power and musical quality of your APEX amplifier while retaining the multi-channel functionality of your home cinema amplifier.

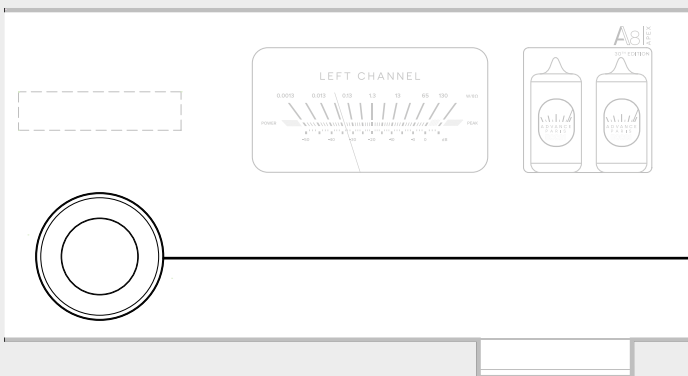

AMP-IN mode can also be activated via the settings menu on your APEX amplifier. To do so, navigate to the following menu:

MENU / SYSTEM SETTINGS / AMP IN / ON

It is advisable to perform an acoustic calibration of the entire system using your home cinema amplifier's calibration process to balance the level of all speakers. Refer to your home cinema amplifier's manual.

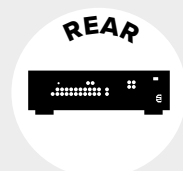



EN

CONTENTS

DESCRIPTION

CONNECTIONS

USAGE

SETTINGS

FAQ

APPENDICES

Using your turntable

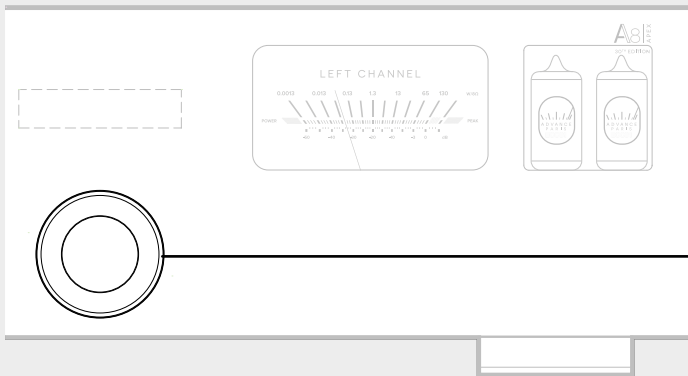

Select the Phono input on your APEX amplifier via the APEX amplifier input menu or the remote control.





CONTENTS	DESCRIPTION	CONNECTIONS	USAGE	SETTINGS	FAQ	APPENDICES
----------	-------------	-------------	-------	-----------------	-----	------------

Settings menu (remote control)36
Settings menu (multifunction control)37
Subwoofer Output configuration38
Display brightness39
Automatic standby mode40
Tone and balance41
Loudness42
Volume when switched ON43
Standby button44
Disable HDMI CEC control45
High-Bias Setting46
Reset.47

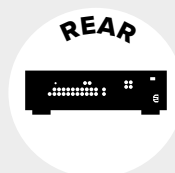



EN

CONTENTS

DESCRIPTION

CONNECTIONS

USAGE

SETTINGS

FAQ

APPENDICE

Settings menu (remote control)

By pressing the «MENU» button on the remote control, you can access the various settings menus for your APEX amplifier.

To return to the previous level, briefly press the 'MENU' button.

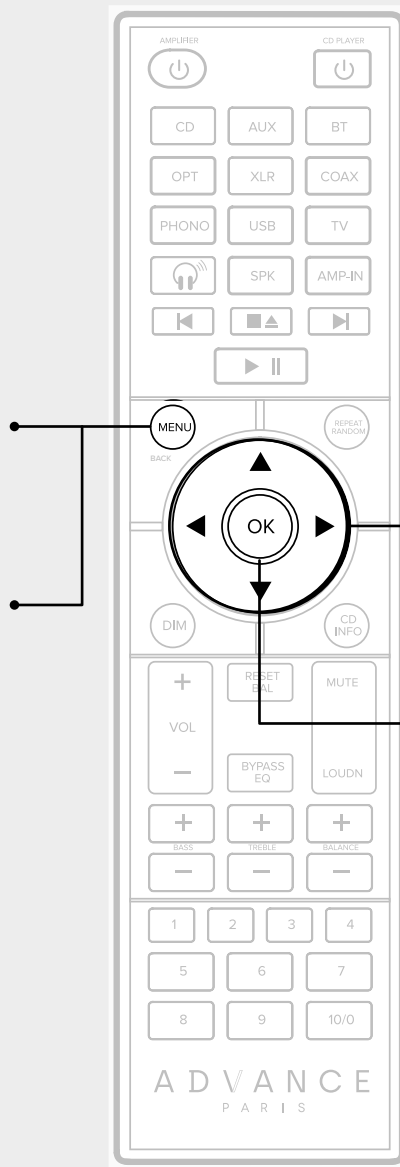

By pressing the directional buttons on the remote control, you can access the various settings menus for your APEX amplifier.

To enter a specific setting, you must briefly press the central «OK» button.





EN

CONTENTS

DESCRIPTION

CONNECTIONS

USAGE

SETTINGS

FAQ

APPENDICES

Settings menu (multifunction control)

How do I access the settings menu using the multifunction control?

By pressing and holding the multifunction control for more than one second, you can access the various settings menus on your APEX amplifier.

By turning the multifunction control, you can scroll through the various entries in the settings menu.

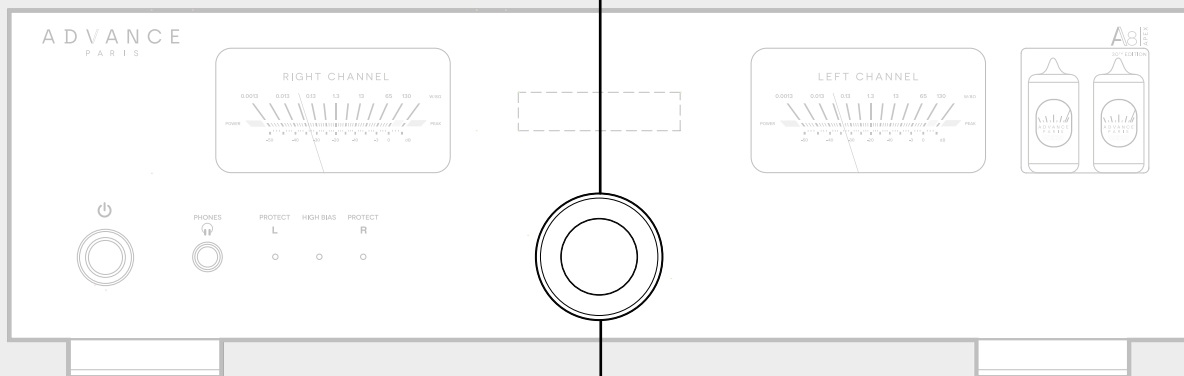

To access a specific setting, you must briefly press the multifunction control.

To return to the previous level, you must press and hold the multifunction control.





CONTENTS

DESCRIPTION

CONNECTIONS

USAGE

SETTINGS

FAQ

APPENDICE

Configuration of the subwoofer output

The subwoofer output is cut at 200 Hz with a slope of 12 dB per octave, $Q = 0.7$.

You need to configure volume and cut-OFF frequency on the subwoofer back panel.





Brightness

DIM on the remote control

You can adjust the brightness of the VU meters and the display by repeatedly pressing the DIM button.

The brightness of the front panel buttons is not adjustable.

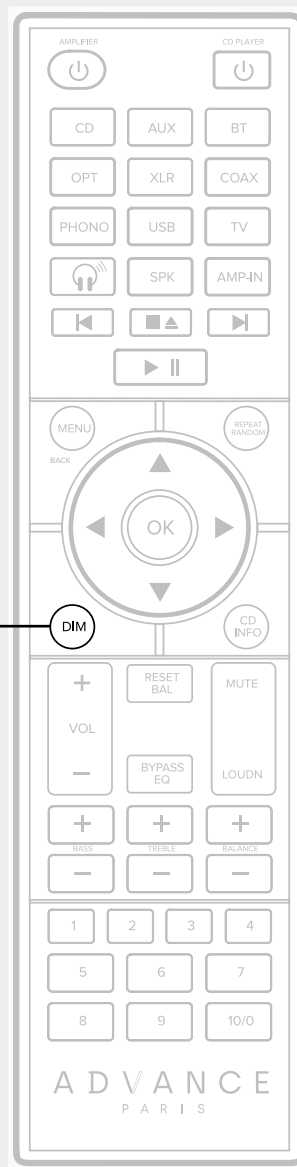



CONTENTS

DESCRIPTION

CONNECTIONS

USAGE

SETTINGS

FAQ

APPENDICE

Auto standby mode

Product display

MENU / APD SET

You can configure your amplifier to switch off automatically after a certain period of time without a signal.

OFF / 5 minutes / 10 / 20 / 30 / 60

When set to OFF, your amplifier will never switch off by itself.





Tone and Balance

Remote control / product display

You can adjust the treble, bass and balance using the remote control or directly on the device. To adjust the tone settings on the device, you must use the device menu:

MENU / TONE

The remote control allows you to adjust the bass, treble and balance settings.

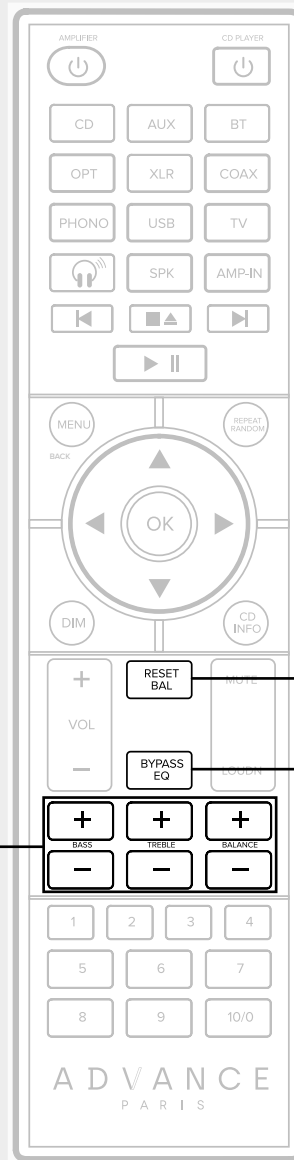

The Reset Bal button resets the balance to the centre.

The Bypass EQ button is active, or deactivate your settings.





CONTENTS

DESCRIPTION

CONNECTIONS

USAGE

SETTINGS

FAQ

APPENDICE

Loudness

Remote control / product display

MENU / TONE

On the remote control, the Loudness button allows you to enable or disable the Loudness feature.

Loudness compensates for the loss of sensitivity in the ears at low and high frequencies when listening at low volume.

Your amplifier will dynamically correct bass and treble frequencies based on your listening volume to achieve the most natural sound balance possible: at low volume, the correction is significant; at medium volume, the correction is moderate; at high volume, the correction is zero.





CONTENTS

DESCRIPTION

CONNECTIONS

USAGE

SETTINGS

FAQ

APPENDICES

Volume level when switched ON

Product display

MENU / VOL SET

When set to ON, you can activate a specific volume each time you start up your APEX amplifier. When set to OFF, your APEX amplifier will start up with the same volume as when it was put into standby mode.

MENU / VOL SET / VOL DEF

You can set the start-up volume level here once you have set the previous step to ON.





Standby button

Product display

You can deactivate the red light on the Standby button on the front of your amplifier. When in standby mode, the Standby button will no longer light up red.

You need to go to the product menu :

MENU / STB LED





CONTENTS

DESCRIPTION

CONNECTIONS

USAGE

SETTINGS

FAQ

APPENDICES

Disable HDMI CEC control

Product display

MENU / CEC CTL

When set to ON, your amplifier will respond to commands sent by your television to coordinate the switching on or standby mode of the APEX amplifier and television.

When set to OFF, your APEX amplifier will not respond. However, the volume controls are always active regardless of the CEC CONTROL setting.





EN

CONTENTS

DESCRIPTION

CONNECTIONS

USAGE

SETTINGS

FAQ

APPENDICE

High-Bias Setting

Your APEX amplifier uses class AB amplification. The APEX amplifier therefore operates in class A at low power levels (below 5W) and in class B at higher power levels. It has a bias setting that can be configured to two positions: OFF and ON.

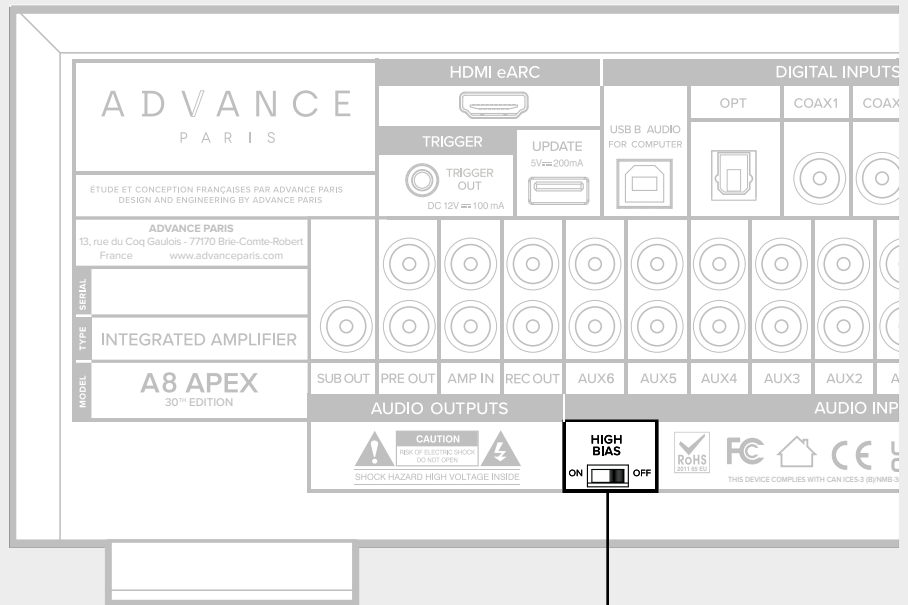

> OFF is the “normal” setting.

> ON is the “High-Bias” setting with higher Class A power (approximately 8-10 W).





CONTENTS

DESCRIPTION

CONNECTIONS

USAGE

SETTINGS

FAQ

APPENDICES

Reset

Product display

MENU / RESET

If necessary, you can reset all settings on the APEX amplifier to their factory defaults.





CONTENTS	DESCRIPTION	CONNECTIONS	USAGE	SETTINGS	FAQ	APPENDICES
----------	-------------	-------------	-------	----------	------------	------------

Internal software information49
Update50
Frequently asked questions51





CONTENTS

DESCRIPTION

CONNECTIONS

USAGE

SETTINGS

FAQ

APPENDICES

Internal software information

To find out which version of internal software your APEX amplifier is running, you need to go to the following menu:

MENU / SYS INFO

By turning the multifunction control, you can scroll through the information. The internal software corresponds to the «MCU VERSION».





Software update

If an update is required, after installing the update file on a USB key, you must connect this key to the UPDATE port located at the rear of the APEX amplifier.

Start the update by going to the APEX amplifier menu:

MENU / UPGRADE / MCU UPD

The amplifier will start the update and switch to standby mode once the update process is complete. The USB key must be formatted in FAT (possible from Apple OS and Windows).

NOTE: Updates are available on the Advance Paris website.
See the product page: www.advanceparis.com





Frequently asked questions

- **The power supply does not switch on/off**
 - > Check that the mains cable is properly connected.
 - > Check that the mains switch on the rear of the APEX amplifier is in the ON position.
- **Operations cannot be performed via the remote control.**
 - > Check/replace the batteries in the remote control.
- **No sound is emitted**
 - > Check that you have selected the input you want to listen to
 - > Check that the «MUTE» function is not activated
 - > Check that the speaker output (A or B) is enabled in the settings menu.
- **The desired audio is not being played**
 - > Check that you have selected the correct input.
- **The sound is distorted or there is unwanted noise**
 - > Contact your after-sales service
 - > Possible need to change the preamplifier tubes
- **The sound from my record player is not good.**
 - > Ensure that your turntable is correctly connected to the PHONO input on the APEX amplifier.
 - > Check the adjustable settings on the turntable.
- **No sound from a USB stick plugged into the rear port**
 - > The USB A «UPDATE» port is not compatible with audio files; it is only intended for updates when necessary.
- **I do not have sound from my television on my speakers.**
 - > If you have used an HDMI cable between the APEX amplifier and your television, check that the CEC/HDMI ARC (or e-ARC) feature is enabled on your television. Set the television's audio output to stereo (or PCM). Refer to the television's manual.

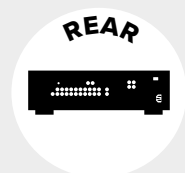



Glossary

A-BTC	Optional Bluetooth module from Advance Paris to be inserted into the dedicated socket on the rear of Advance Paris amplifiers to enable connection of Bluetooth sources or headphones.
Display	Screen located on the front of the amplifier for displaying information (source, volume, settings, etc.).
AMP-IN	Input allowing the APEX amplifier to be used as a power unit, for example in a home cinema system.
Amplifier (amp)	A device that amplifies audio signals from various sources in order to power loudspeakers.
Terminal	Connectors located at the rear of the amplifier for connecting one pair of speakers.
Bluetooth	Wireless transmission technology enabling connection of a compatible device via the A-BTC module.
Standby button	Button for switching the amplifier on or putting it into standby mode.
Speaker cables	Cables used to connect the speakers to the amplifier terminals.
Coaxial (digital input)	Digital input using a coaxial cable to transmit sound.
Power cord	Power cable for connecting the amplifier to an electrical socket.
AUX input	Stereo analogue inputs for connecting various sources.
MM phono input	Input specially designed for turntables equipped with moving magnet (MM) cartridges.
Optical Input	Digital inputs using an optical cable (Toslink).





CONTENTS

DESCRIPTION

CONNECTIONS

USAGE

SETTINGS

FAQ

APPENDICES

Spades	Type of connector for speaker cables that attaches around the terminal block.
GROUND	Ground terminal to reduce interference noise when connecting a turntable.
HDMI ARC eARC	HDMI connection for transmitting sound between the television and the amplifier, with volume control and standby function.
Infrared (IR)	Infrared transmission system enabling the remote control to communicate with the amplifier.
Mains switch	Main switch to turn the device on or off completely.
PRE-OUT	Output enabling the audio signal to be sent to an external power amplifier.
RCA	Red and white analogue connectors used for audio connections.
REC-OUT	Output for connecting a recording device.
Subwoofer	Speaker designed to reproduce very low frequencies (bass). It complements the main speakers to provide greater depth and impact in the bass range. Can be connected in single (mono) or dual (stereo) configuration depending on the amplifier settings.
Trigger IN	Connectors for synchronising the switching on or off of the amplifier with other devices.
USB type B	Input allowing you to connect a computer to use the amplifier as a USB sound card.



CONTENTS

DESCRIPTION

CONNECTIONS

USAGE

SETTINGS

FAQ

APPENDICES

Dimensions / Weight

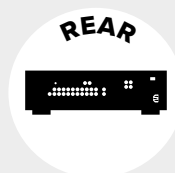
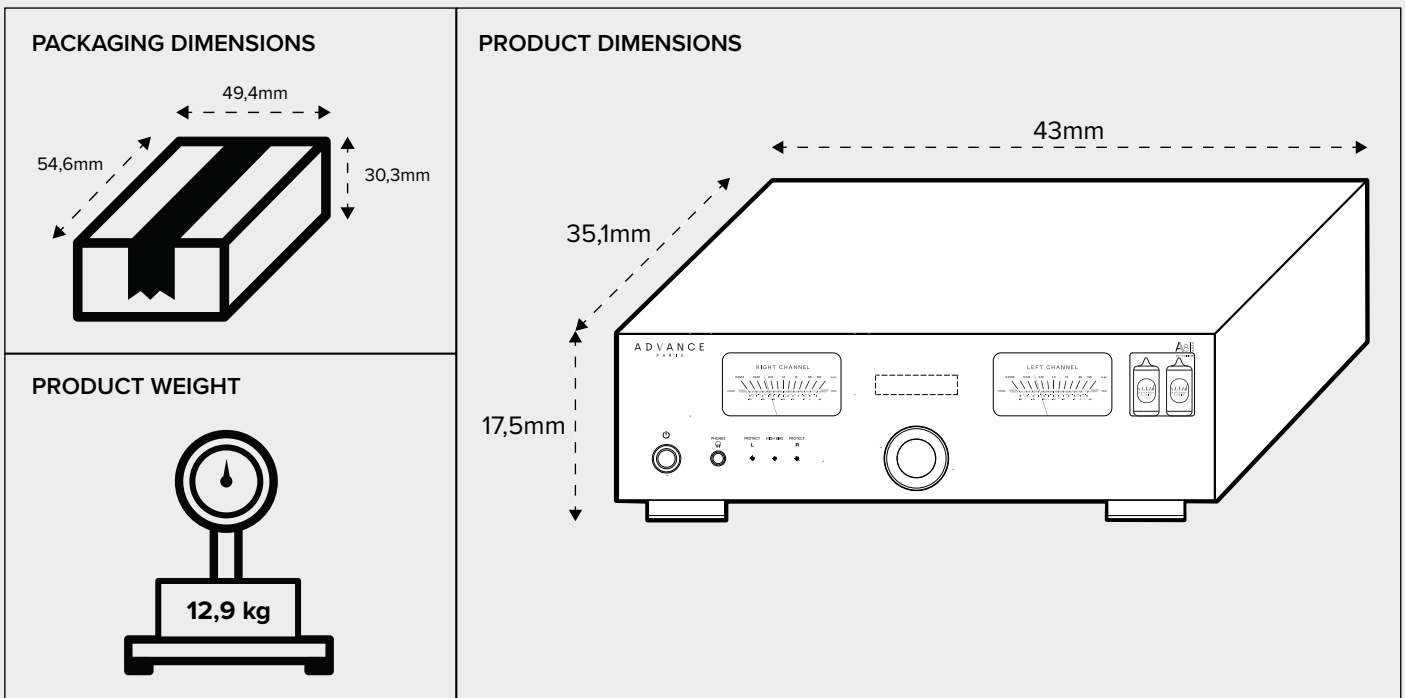



Specifications

Output power 8Ω	76W (THD+N 1%, 1kHz, 2 channels running)
Output power 4 Ω	110W (THD+N 1%, 1kHz, 2 channels running)
Frequency response (+/-1dB)	20 Hz > 80 kHz (16W, 8 Ω)
THD+N distortion	0,03% (1 kHz, 52W, 8 Ω)
Signal-to-noise ratio	100dB (1 kHz, 52W, 8 Ω)
AC input compatibility	115/230V 50/60Hz with switch
Transformer type/power	Toroidal / 240VA
DAC	ESS9018
Digital inputs	Optical : 24bit - 192kHz PCM Coaxial : 24bit - 192kHz PCM USB audio : 24bit/192 kHz PCM - DSD64 - DSD128 HDMI eARC : PCM Stereo
A-BTC entry	For A-BTC Bluetooth receiver (optional)
Analogue inputs	RCA LINE level (7x) - PHONO MM level (1x) + GROUND
Analogue outputs	RCA : REC-OUT (x1), PRE-OUT (x1), SUB-OUT (x1)
Headphone jack	6.35mm jack
High-Bias	Yes, ON/OFF switch
Update	Via USB key on the «UPDATE» port
Speaker terminals	Screw terminals compatible with bare cable, spade and banana plugs
Remote control	Infrared, REM-19, compatible with A8 APEX and ACD
Trigger socket	(1x) Output, 12V
Product dimensions (WxHxD in cm)	43x13.2x36.3
Packaging dimensions (WxHxD in cm)	54.5x26.5x46
Gross weight (kg) / Net weight (kg)	12.5 / 9.4
Model No.	A8 APEX 30TH EDITION
EAN code	3 760 179 292 756

