



ACOUSTICS

CONCEPT  
SERIES



## CONCEPT SERIES

### The Concept Series. No artificial colouring.

Since its founding in 2006, Q Acoustics has built an unrivalled reputation for designing, engineering and manufacturing innovative, high-performance and class-leading loudspeakers at every price-point. This ongoing and concerted demonstration of excellence has led to the Concept series.

This series is comprised of the Concept 30 bookshelf, Concept 50 floorstander, the flagship Concept 300 standmount and top-of-the range Concept 500 floorstanding speaker, alongside the Concept 90 centre channel for home cinema. These speakers are a culmination of all the technological advancements and innovations the company has achieved over the past 15 years and goes beyond anything that Q Acoustics has accomplished before. We confidently believe these beautifully styled speakers provide a level of sonic performance previously thought impossible at these price points.

The objective of any good hi-fi system is to reproduce a convincing live performance in the comfort of your home. The Concept series adopts some of the most advanced and cutting-edge technologies to deliver pure audio excellence and a sensational sound stage.

Natural, powerful and dynamic.



#### Introduction

- Technology
- Design
- The Range
- Home Cinema
- Accessories
- Specifications



## The Concept Series. No artificial colouring.

Every element of acoustic innovation featured in the Concept series is engineered towards designing the 'quietest' cabinet possible. From the pioneering Gelcore™ cabinet construction, the microscopic analysed internal P2P™ bracing through to the unparalleled isolation suspension system base and the unique driver design, our expert engineers have continually created, evolved and refined these technologies. The result is as close to the resonance-free, speaker-design Holy Grail as possible.

Unaffected by internal and external resonances, these speakers deliver focused stereo imaging, accurate audio and an extended holographic soundstage to emulate a live performance in the home.

The design and finish on the Concept family befits a flagship range. Showcasing sophisticated design lines and stunning, premium high gloss finish, all models arrive in three striking multi-lacquers: black, silver and white, with Concept 300 and 500 combining them with luxurious wood veneers.

### Introduction

- Technology
- Design
- The Range
- Home Cinema
- Accessories
- Specifications





CONCEPT SERIES

[Introduction](#)

**[Technology](#)**

[Design](#)

[The Range](#)

[Home Cinema](#)

[Accessories](#)

[Specifications](#)

# TECHNOLOGY

## Gelcore™

Introduced in the original Concept speaker, the Gelcore™ cabinet construction is designed to minimise high-frequency noise. A unique design comprised of a non-setting gel sandwiched between two individual layers, this specially developed adhesive dissipates high-frequency vibrations, generated by the moving drivers, into heat to maintain a focused audio performance, whether watching movies or listening to music.

**Gelcore™ cabinet design features in Concept 30 / 50 / 90**

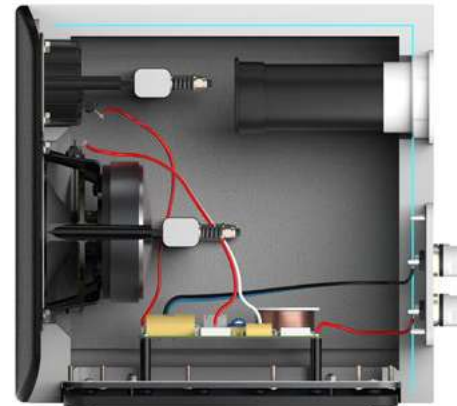

## Dual Gelcore™

The cabinet is comprised of three individual layers - the gaps between each are completely filled, under pressure, by a compliant form of non-setting gel. The two constrained layers convert higher-frequency vibration into heat, which dissipates within the damping gel reducing higher frequency cabinet vibrations in an ultra-quiet cabinet construction.

**Dual Gelcore™ cabinet design features in Concept 300 / 500**

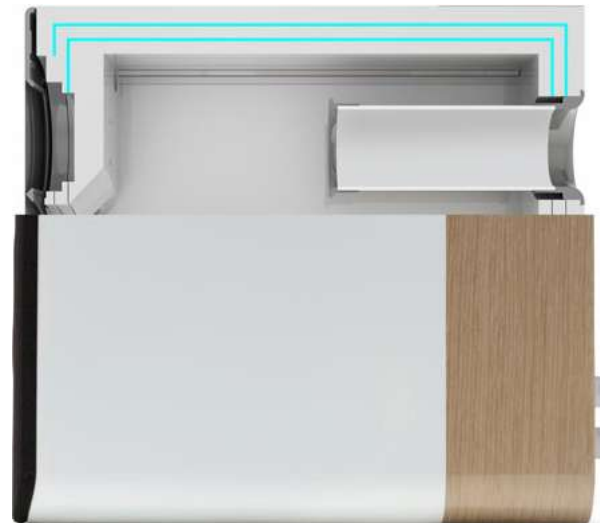

## P2P™ (Point to Point™) bracing

To keep the cabinet as rigid as possible, P2P™ (Point to Point™) internal bracing is employed. First introduced in the Concept 500, reinforcement is fitted to interior areas of the cabinet susceptible to low-end frequency reverberations.

Using Finite Element Analysis and laser interferometry to examine the performance of the cabinet down to a microscopic level, P2P™ bracing has been applied to the speaker cabinet.

Implemented this state-of-the-art technology, Q Acoustics have been able to identify and apply bracing to only the precise points of the cabinet that require additional support and unwanted energy is dissipated rather than transferred throughout the cabinet.

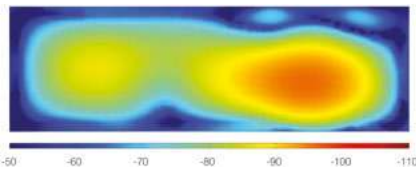

### Conventional bracing

Heat map showing unbraced wall velocity dispersion

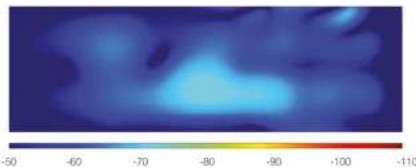

### Point to Point™ bracing

Heat map showing cabinet wall velocity with P2P™ bracing

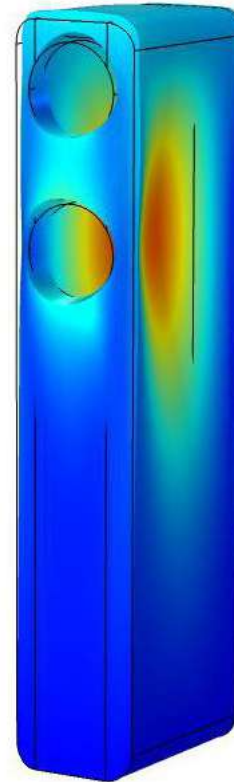

### Conventional bracing

Concept 50 cabinet



### Point to Point™ bracing

Concept 50 cabinet

## HPE™ (Helmholtz Pressure Equalizer™)

Tall loudspeaker enclosures are vulnerable to increased internal pressure caused by standing waves.

These generate unwanted resonances that colour the sound. Originally developed for the top-of-the-range Concept 500 floorstanding speaker, HPE™ (Helmholtz Pressure Equalizer™) tube technology is designed to convert this pressure into velocity and reduce the overall pressure gradient within the speaker enclosure.

Tubes inside the tall cabinet eliminate these performance-affecting vibrations to maintain a transparent soundstage.



Without HPE™

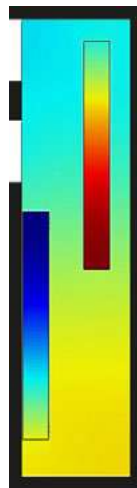

With HPE™

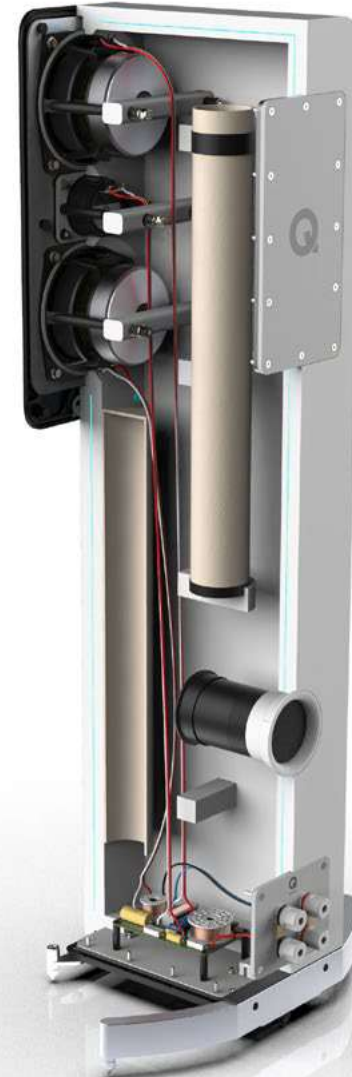

## Isolation Base

### Concept 300

Rigidly coupling a speaker to a stand is crucial to minimising the intensity of vibrational energy and maintain an accurate audio performance. Q Acoustics' expert engineers have developed the Isolation Base plate system that is integrated into the bottom of the Concept 300 cabinet. Not only does it securely anchor the cabinet to the stand but provides a flexible suspension system.

The entire mass of the speaker rests on four springs, damped using a special material called Sylodamp™. A polyurethane elastomer, precisely tailored to the mass of the speaker converts any vibrational energy in the springs into heat. The result is a more controlled but extended bass response and improved stereo imaging.

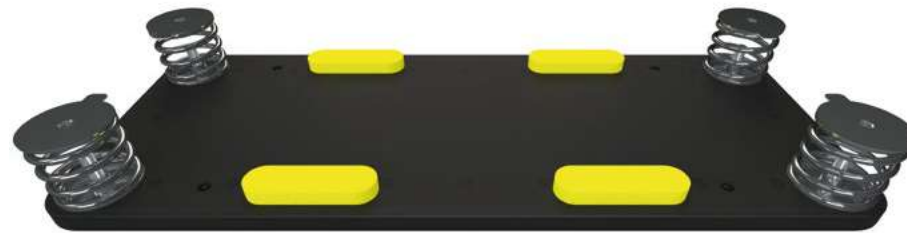

### Concept 30 / 50 / 90

A variation on the hugely effective principle seen on Concept 300, the Concept 30 features a suspension system in the form of a sprung baseplate. Two plates are separated by suspension 'spheres' that effectively isolates the cabinet from interference from external vibrations, providing tighter stereo imaging, while also bringing greater depth.

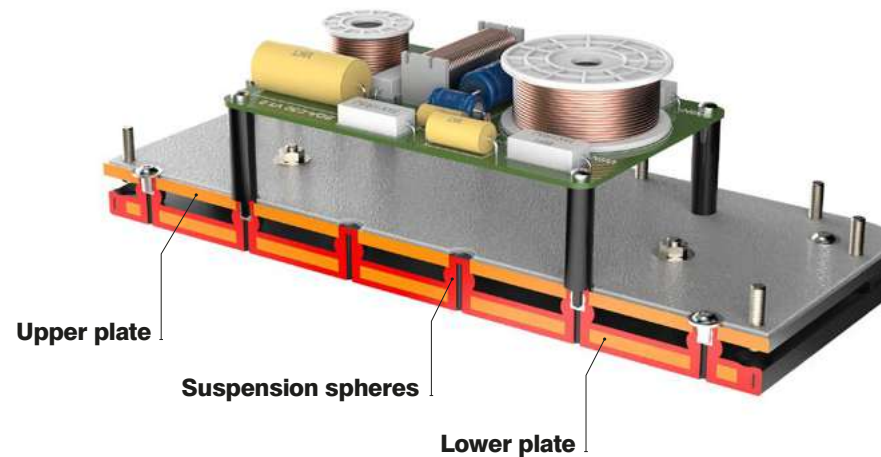



## Crossover design

The crossover design in the Concept 30, 50 and 90 is mounted away from electro-magnetic fields radiated by the drive units. The crossover has been mounted into the isolation base to achieve this so it's not rigidly fixed and has its own suspension system which makes it less susceptible to internal vibrations.

The base is constructed from a non-metallic paper loaded phenolic resin sheet to prevent the induction of eddy currents by the adjacent crossover which could otherwise occur in a metal base



## Bi-Wire Terminals

All models in the Concept series features Bi-Wire terminals on the rear of the cabinet. This means, using a compatible speaker cable, two pair of cables can be run from your power source (amplifier) to the speaker. One set of cables carries the high frequency signals, while the second pair transfers the mid/low frequencies.

The advantage of separating these frequencies through bi-wiring are two-fold: Intermodulation distortion caused by interactions between the high and low frequencies traveling down the cable can be minimised, with the result being noticeable improvement in the clarity of the mid-range.





CONCEPT SERIES

Introduction

Technology

**Design**

The Range

Home Cinema

Accessories

Specifications

# DESIGN



## CONCEPT SERIES

[Introduction](#)

[Technology](#)

**[Design](#)**

[The Range](#)

[Home Cinema](#)

[Accessories](#)

[Specifications](#)

## Style

Understated but effortlessly stylish, the Concept family fits perfectly into your listening environment. The exceptional engineering inside the cabinet is matched by the stunning, premium finish on the outside, that honours the range's flagship credentials. In a world of busy designs, the Concept's form is refreshingly minimalist, with the series available in three exquisite lacquers – white, black and silver.

As befits its top-of-the-range billing, the Concept 500 floorstander and Concept 300 standmount models arrive in a sophisticated dual finish that combines Italian real wood veneers with a striking multiple gloss lacquer – choose from a Silver/Ebony, Black/Rosewood and Gloss white/Light Oak.

Further down the range, the Concept 30, 50 and 90 retain the signature aluminium front baffle plate that made the original Concept speakers so iconic and come in single luxurious white, black and silver gloss lacquer finishes.

## Cabinets

A resonance-free cabinet will endeavour to deliver the most lifelike music or home cinema performance possible. That's why every inch of the Concept series' cabinets are designed to minimise inside and outside influences that can have a detrimental effect on the overall sound it produces.

First introduced on the original Concept, the Gelcore™ cabinet walls are the first line of defence against vibrations, securely reinforced by internal P2P™ (Point to Point™) bracing that bolsters the areas of the cabinet vulnerable to low-end frequency reverberations, while the floorstanding models feature HPE™ (Helmholtz Pressure Equalizer™) tubing to dissipate standing waves.

Further resonance-dampening designs have been introduced into the Concept 30, 50 and 90 models including a unique baffle mounted driver assembly, a fully hermetically sealed and mechanically isolated high-frequency driver and a crossover design mounted on the isolation base, to minimise any microphonic pick up.

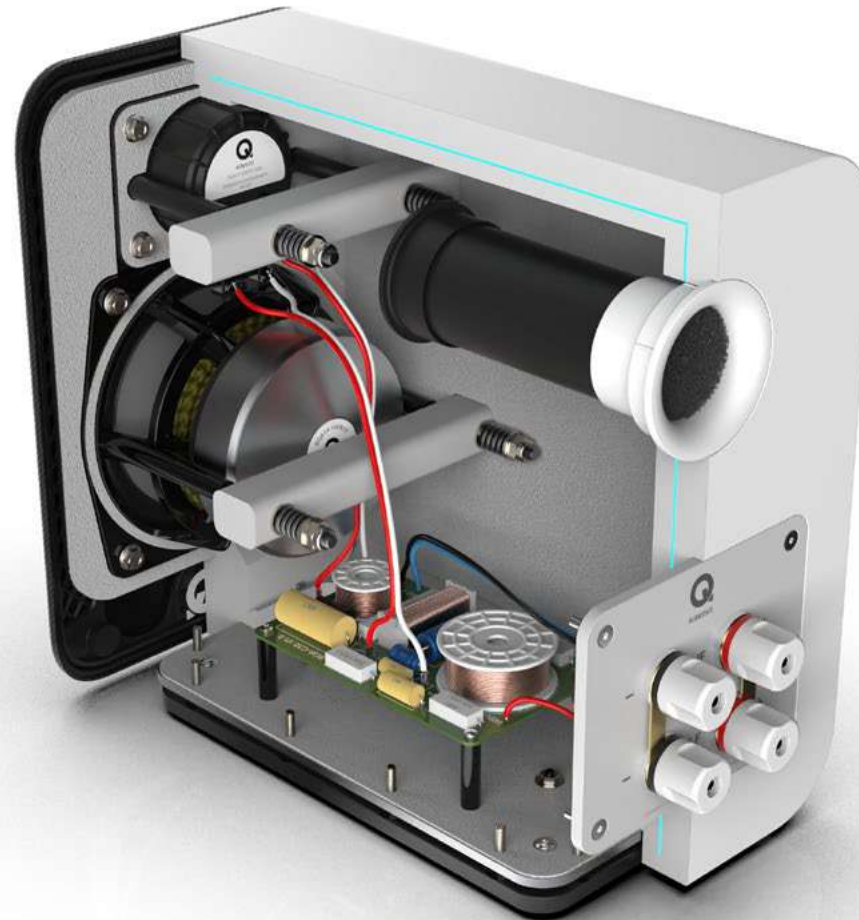



CONCEPT SERIES

- Introduction
- Technology
- Design
- The Range**
- Home Cinema
- Accessories
- Specifications

# THE RANGE



# Concept 30

A sophisticated standmount speaker, that takes cutting-edge acoustic technology and design cues pioneered in the flagship 300 and 500 to deliver a high-end sound, while featuring audio innovations that belie its price point.



## Concept 30

Harbouring the core cabinet technologies from its flagship brethren, the Concept 30 also features new acoustic and structural designs to further reduce unwanted resonances.

Designed as an integral part of the mechanical structure of the cabinet, both the 125mm mid/bass and 25mm tweeter drivers are new, ground-up designs. The drive units are fixed to a remarkably stiff 3mm aluminium baffle plate by pretensioned studs before it is fitted to the cabinet - this gives the correct acoustic seal, dampening vibrations and minimising structural coupling.



Black

Silver

White



## Concept 30

The newly introduced tweeter is hermetically sealed and mechanically isolated from the baffle, which means lower distortion and a lower crossover point for seamless integration through the crossover region. At 30.5mm, the larger mid/bass driver voice coil increases motor strength resulting in a 50% increase in power handling over a comparable driver with 25.4 mm voice coil, making the speaker easier to drive and pair with different amplifiers.

Lastly, the crossover itself is mounted to the isolation base, keeping it free of sound-affecting vibrations and away from the electro-magnetic influence of the drivers themselves.

The front-facing brushed aluminium plate mirrors the signature design of the original classic Concept speakers, with the curved cabinet edges continuing the new design language introduced on Concept 300 and 500. The striking optional Q FS75 stand is also influenced by the Concept 300's Tensegrity design, combining eye-catching industrial design with anti-resonance properties.

- Gelcore™
- P2P™ (Point to Point™) bracing
- Isolation Base
- Bi-Wire Terminals

### High Frequency Drivers

---

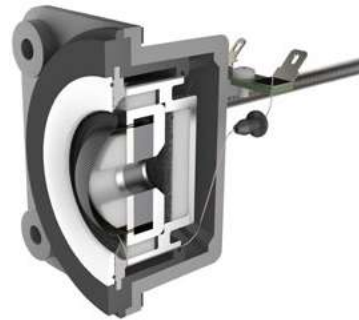

### Mid/Bass Drivers

---

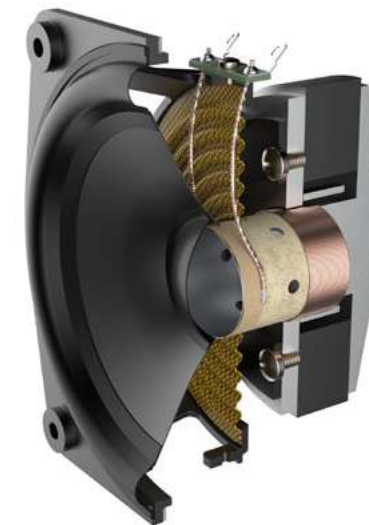





## CONCEPT SERIES

[Introduction](#)

[Technology](#)

[Design](#)

**[The Range](#)**

[Home Cinema](#)

[Accessories](#)

[Specifications](#)

# Concept 50

A sonic step-up from the Concept 30, this elegant floorstander takes everything great about its standmount brother but delivers more powerful audio, a deeper soundstage and increased bass extension through its leading-edge, low resonance cabinet.





## Concept 50

Suited to larger spaces, the Concept 50 offers a truly high-end home audio performance without the high-end price tag. In common with the Concept 30 and 90, this floorstander accommodates all the ultra-low resonance technologies synonymous with this flagship series – Gelcore™ cabinet walls, P2P™ (Point to Point™) bracing, a de-coupled, hermetically sealed tweeter design, the baffle mounted driver assembly and the isolation-base crossover design.

Boasting a higher sensitivity for enhanced dynamics, this floorstander thrills with its sheer musicality and uncannily realistic soundstage. You will hear the separation of the instruments as if located on a live stage for an immersive listening experience in the home.



Black

Silver

White



## Concept 50

Like the Concept 30 and 90, this floorstanding model features brand new, state-of-the-art drivers designs, developed specifically for these speakers. The 25mm tweeter is hermetically sealed and mechanically isolated from the baffle, while the internal back chamber is carefully vented for lower distortion in the crossover region. And the two 125mm mid/bass drivers has a big 30.5mm voice-coil for increased motor strength and, consequently, improved power handling.

The very nature of the Concept 50 tower design can introduce undesirable standing waves within the cabinet. By employing an HPE™ (Helmholtz Pressure Equalizer™) tube design, first introduced in the Concept 500, pressure is converted to velocity to eliminate these performance-affecting vibrations and to help deliver the ideal frequency response.

All the anti-resonance innovations allow the state-of-the-art complement of drivers free to get on with the job of delivering the most realistic, most involving sound ever heard at this price-point.

- Gelcore™
- P2P™ (Point to Point™) bracing
- HPE™ (Helmholtz Pressure Equalizer™)
- Isolation Base
- Bi-Wire Terminals

### High Frequency Drivers

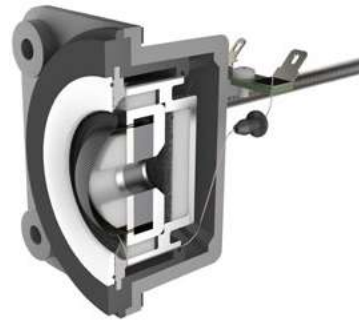

### Mid/Bass Drivers

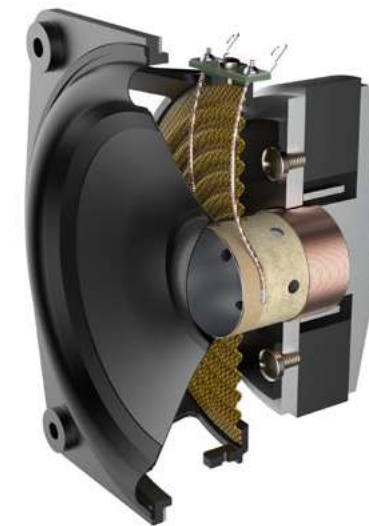



CONCEPT SERIES

[Introduction](#)

[Technology](#)

[Design](#)

**[The Range](#)**

[Home Cinema](#)

[Accessories](#)

[Specifications](#)

## Concept 90

At the heart of a Concept 5.1 home cinema set-up, the Concept 90 is our most high-performance centre channel speaker yet. Able to deliver astonishingly dynamic and ultra-clear dialogue, this speaker is the star of the Concept home cinema range.



## Concept 90

A centre channel speaker in a 5.1 home cinema set-up plays a crucial role to convey a realistic surround sound experience. More than just supporting the front left and right channel speakers, a centre channel anchors the dialogue while also seamlessly being part of the whole soundstage. As a key player in the Concept 5.1 package, the Concept 90 is our most advanced and striking centre channel speaker, featuring many anti-resonance technologies that appear in its Concept stablemates to deliver a focused but captivating cinema sound.

Matching the design profile of the Concept 30 and 50, the Concept 90 arrives in a trio of finishes designed to blend into any Concept 5.1 speaker system you choose to assemble from the range. At the forefront of any surround sound set-up, this stylish centre channel will look at home perched on any cabinet in any interior space.



Black



Silver



White

## Concept 90

Boasting a three-way design with two 125mm mid/bass drivers flanking a 25mm tweeter, the Concept 90 brings ultra-clear dialogue and spellbinding effects to movie watching sessions through its specially developed driver designs. With sound synergy important in a home cinema speaker system, the Concept 90 harbours the same hermitically sealed and decoupled tweeter enclosure and driver assembly baffle-mounted design as the Concept 30 and 50. The same isolation base, featuring two plates separated by suspension spheres, is also present to isolate the cabinet from external resonances – a crucial design when the speaker is placed straight onto a TV cabinet.

All these resonance eliminating innovations are housed in a Gelcore™ cabinet design to deliver a speaker low on interior and exterior influences that can colour the sound. It ensures the Concept 90 can dispatch crystal clear dialogue and improved depth of sound that will elevate the film watching experience.

- Gelcore™
- Isolation Base
- Bi-Wire Terminals

### High Frequency Drivers

---

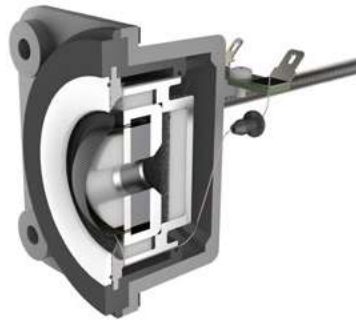

### Mid/Bass Drivers

---





[Introduction](#)

[Technology](#)

[Design](#)

**[The Range](#)**

[Home Cinema](#)

[Accessories](#)

[Specifications](#)

## Concept 300

This flagship standmount makes a cutting-edge design statement, while harbouring state-of-the-art acoustic innovations from its bigger brother, the Concept 500. Fused with groundbreaking speaker stand technology and the Concept 300 is Q Acoustics' most progressive speaker yet.



## Concept 300

The brief for Concept 300 is simple, yet staggeringly ambitious: to build on the runaway success of the floorstanding Concept 500 and deliver a standmounting alternative that's at once more affordable, of utterly uncompromised performance and of stylish, understated elegance.

This combination of rigorous engineering, uncompromised industrial design and aspirational aesthetics makes Concept 300 the most fully realised loudspeaker Q Acoustics has yet delivered.

In combination with the equally meticulous Tensegrity stand, Concept 300 not only advances loudspeaker performance at its price, it also represents a redefinition of the relationship between a loudspeaker and its support.





## Concept 300

The design, build and finish of Concept 300 is as sophisticated and high-quality as the sound itself.

The dual-finish cabinet is designed to interact comfortably with any interior decor vocabulary while maintaining the Q Acoustics' clean, contemporary design language. Concept 300 combines real wood veneers with multiple gloss lacquer coats to produce three stunning finishes: Black and Rosewood, Silver and Ebony, or White and Oak.



Black / Rosewood

White / Light Oak

Silver / Ebony



## Concept 300

The striking Concept 300 speakers host a wealth of technology, not only those that have secured Concept 500s place as an extraordinary floorstanding loudspeaker, but new innovations resulting in the purest sound Q Acoustics have achieved from any standmounted speaker yet.

- Gelcore™
- P2P™ (Point to Point™) bracing
- HPE™ (Helmholtz Pressure Equalizer™)
- Isolation Base
- Bi-Wire Terminals



### High Frequency Drivers



### Mid/Bass Drivers





CONCEPT SERIES

- Introduction
- Technology
- Design
- The Range**
- Home Cinema
- Accessories
- Specifications

# Concept 500

A top-of-the-range loudspeaker that is at once, stylish, contemporary, exquisite-sounding and astonishingly accurate to deliver a landmark live performance sound in the home.



## Concept 500

Designed to appeal to discerning audiophiles, the Concept 500 achieves a perfect balance between art and science. It is a loudspeaker that is at once, stylish, contemporary, exquisite-sounding and astonishingly accurate. It couples low directivity with wide bandwidth, good sensitivity and sensible impedance. This makes the Concept 500 both room friendly and an easy load to drive, allowing amplifiers to deliver their best performance.

To create a stereo soundstage which gives as good an impression of width, depth and height as that found in a live performance requires high quality drive units, a well-designed crossover and a precisely constructed cabinet. To achieve this, Q Acoustics formed a truly talented team with many years of experience in the design, engineering and manufacture of world-class loudspeakers. A combination that resulted in a state-of-the-art loudspeaker worthy of any high-end system.





## Concept 500

The dual-finish cabinet of the flagship Concept 500 is designed to interact comfortably with any interior decor vocabulary while maintaining the Q Acoustics' clean, contemporary design language.

Concept 500 combines Italian real wood veneer accents with multiple premium gloss lacquer coats to produce three stunning finishes: Black/Rosewood, Silver/Ebony, or White/Light Oak.



Black / Rosewood



White / Light Oak



Silver / Ebony



## Concept 500

Replicating that live stage performance in your home has been achieved by implementing some of the most ground-breaking anti-resonance innovations ever seen on a loudspeaker. By employing a Dual Gelcore™ cabinet construction, P2P™ (Point to Point™) interior bracing and HPE™ (Helmholtz Pressure Equalizer™) tube technology, internal vibrations are diminished to produce a laser-focused audio performance.

The result is a dynamic, lifelike and powerful soundstage that will transport the listener to a live setting.

- Gelcore™
- P2P™ (Point to Point™) bracing
- HPE™ (Helmholtz Pressure Equalizer™)
- Bi-Wire Terminals

### High Frequency Drivers

---



### Mid/Bass Drivers

---

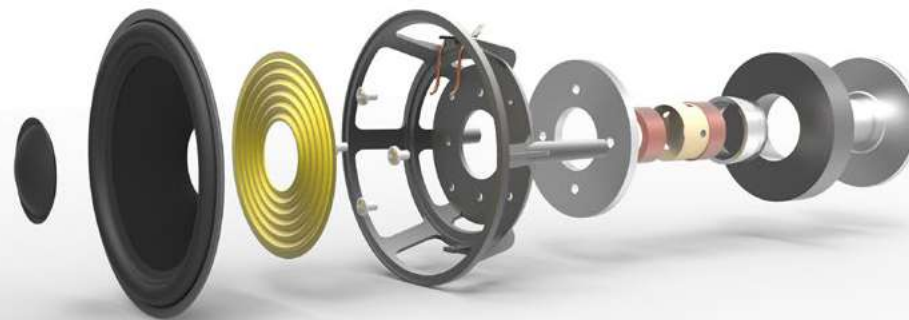



CONCEPT SERIES

[Introduction](#)

[Technology](#)

[Design](#)

[The Range](#)

**[Home Cinema](#)**

[Accessories](#)

[Specifications](#)

# HOME CINEMA





ACOUSTICS

CONCEPT SERIES

- Introduction
- Technology
- Design
- The Range
- Home Cinema**
- Accessories
- Specifications

## Concept Home Cinema

As class-leading stereo speakers, the Concept series can also form the ultimate enveloping, absorbing 5.1 surround-sound system. With the addition of the matching Concept 90 centre channel speaker and Q B12 subwoofer for seismic low-end sounds, home cinema buffs can create their own Concept set-up or choose our curated Concept 50 5.1 package. Whatever Concept speaker configuration you choose, movie-watching at home will be elevated to cinematic levels full of power, nuance and realism.





ACOUSTICS

CONCEPT SERIES

Introduction

Technology

Design

The Range

**Home Cinema**

Accessories

Specifications

## Concept 30 5.1 Package

Designed for movie fans who want more discreet front and rear satellite speakers in the form of the compact Concept 30 standmounts, this home cinema speaker system will still pack a heavy cinematic punch but also deliver a convincing and coherent presentation brimming with nuanced detail. No matter the complexity of the sound, this set-up will take it in its stride.

The package includes:

4 x Concept 30 standmount speakers  
(two at the front (l/r), two at the rear (l/r))

1 x Concept 90 centre channel speaker

1 x Q B12 active subwoofer

Available in black and white finishes.





## Concept 50 5.1 Package

Bringing even more scale and widescreen sound to home movie-watching sessions, this package ramps up the intensity and entertainment levels to command your attention.

The addition of two Concept 50 floorstanding speakers at the front end boosts the power and dynamics, all without sacrificing any insight and subtlety. This 5.1 set-up is as agile and sophisticated as it is commanding and all-encompassing.

The package includes:

2 x Concept 50 (front, left and right)

2 x Concept 30 (rear, left and right)

1 x Concept 90 centre channel speaker

1 x Q B12 active subwoofer

Available in black and white finishes.





CONCEPT SERIES

- Introduction
- Technology
- Design
- The Range
- Home Cinema
- Accessories**
- Specifications

# ACCESSORIES

## Accessories / Stands / Brackets



### Q FS75 speaker stand

Designed for **Concept 30**

Inspired by the ground-breaking Tensegrity stand developed by for the Concept 300 loudspeaker, this stand minimises resonances from the floor to the speaker cabinet (and vice versa). The Concept series speakers are compatible with third party stands.

**Overall dimensions H/W/D**

638 x 286 x 338mm (25.1 x 11.3 x 13.3in) per stand

**Carrying weight**

2.3kg / 5lbs per stand



### Q WB75 wall bracket (single)

Designed for **Concept 30/Concept 90**

A sturdy wall bracket boasting a 'tilt and turn' mechanism, a Concept 30 speaker can be mounted almost flat to the wall or angled down or sideways. Available in black and white finishes.



### Tensegrity stand (pair)

Designed for **Concept 300**

Redefining the relationship between the speaker and the stand, by employing the Tensegrity principle this new loudspeaker support system than a traditional speaker stand. A universal top base plate is supplied for compatibility with other brand standmount speakers.

**Overall dimensions H/W/D**

690 x 492 x 430mm (27.1" x 19.3" x 16.9") per stand

**Top plate dimensions W/D**

60 x 240mm (6.3" x 9.4")

**Carrying weight**

20kg / 44lbs (per speaker)



### QED Bi-Wire speaker cables

Designed for **all Concept speakers**

Bi-wiring your Concept speakers will enhance mid-range clarity and reduce distortion. QED's range of class-leading bi-wire cables cater for every budget.

**Visit » [qed.co.uk](http://qed.co.uk)**



CONCEPT SERIES

Introduction

Technology

Design

The Range

Home Cinema

Accessories

**Specifications**

# SPECIFICATIONS



**Concept 30**

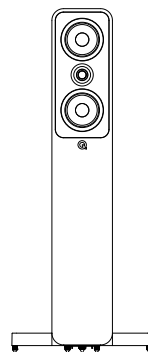

**Concept 50**

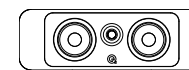

**Concept 90**

	<b>Concept 30</b>	<b>Concept 50</b>	<b>Concept 90</b>
<b>Bass unit</b>	1 x 125 mm (5.0 in)	2 x 125 mm (5.0 in)	2 x 125 mm (5.0 in)
<b>Treble unit</b>	1 x 25 mm (0.9 in)	1 x 25 mm (0.9 in)	1 x 25 mm (0.9 in)
<b>Frequency response (-6dB)</b>	54 Hz - 30 kHz	42 Hz - 30 kHz	67 Hz - 30 kHz
<b>Nominal impedance</b>	6 Ω	6 Ω	6 Ω
<b>Minimum impedance</b>	3.9 Ω	3.6 Ω	3.7 Ω
<b>Sensitivity (2.83V @ 1kHz)</b>	87 dB/w/m	90.5 dB/w/m	90 dB/w/m
<b>Recommended amplifier power</b>	25-100 W	25-150 W	25-150 W
<b>Crossover frequency</b>	2.4 kHz	2.1 kHz	2.1 kHz
<b>Distortion (120Hz - 20kHz, @2.83Vrms)</b>	<0.2%	<0.2%	<0.2%
<b>Effective volume</b>	7.0 L	28.8 L	11 L
<b>Dimensions HxWxD (per loudspeaker)</b>	284 x 180 x 319 mm (11.2 x 7.1 x 12.6 in)	Inc spikes and stabiliser: 1025 x 418 x 319 mm (40.4 x 16.5 x 12.6 in)  Cabinet width: 180 mm (7.1 in)	184 x 550 x 259 mm (7.2 x 21.7 x 10.2 in)
<b>Weight (per loudspeaker)</b>	7.9 kg (17.4 lbs)	22.9 kg (50.5 lbs)	12.3 kg (27.1 lbs)

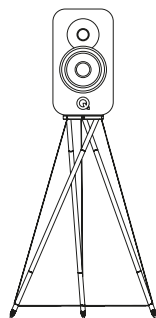

**Concept 300**

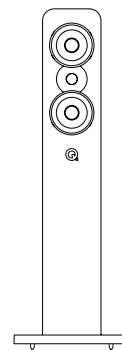

**Concept 500**

<b>Bass unit</b>	1 x 165 mm (6.5 in)	2 x 165 mm (6.5 in)
<b>Treble unit</b>	1 x 28 mm (1.10 in)	1 x 28 mm (1.10 in)
<b>Frequency response (-6dB)</b>	55 Hz - 30 kHz	41 Hz - 30 kHz
<b>Nominal impedance</b>	6 Ω	6 Ω
<b>Minimum impedance</b>	4.7 Ω	3.7 Ω
<b>Sensitivity</b>	84 dB/w/m	90 dB/w/m
<b>Recommended amplifier power</b>	25-200 W	25-200 W
<b>Crossover frequency</b>	2.5 kHz	2.5 kHz
<b>High Frequency Level</b>	+ or - 0.5dB above crossover	+ or - 0.5dB above crossover
<b>Distortion</b>	<0.2%	<0.2%
<b>Effective volume</b>	11.4L	40.7L
<b>Dimensions HxWxD (per loudspeaker)</b>	Cabinet: 355 x 200 x 400 mm (14 x 7.9 x 15.7 in) Stand: 690 x 492 x 430 mm (27.2 x 19.4 x 16.9 in)	1150 x 400 x 350 mm (45.27 x 15.74 x 13.77 in)
<b>Weight (per loudspeaker)</b>	14.5 kg (31.9 lbs)	42 kg (92 lbs)

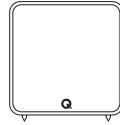

**Q B12 Subwoofer**

<b>Driver unit</b>	1 x 305 mm (12.0 in)
<b>Peak amplifier power</b>	440W
<b>Continuous amplifier power</b>	220W
<b>Power type</b>	Class D
<b>Frequency response (-6dB)</b>	28 Hz - 300 Hz
<b>Input impedance</b>	13 kΩ
<b>Sensitivity</b>	150 mV
<b>Crossover frequency</b>	40Hz – 250Hz
<b>Enclosure type</b>	Infinite baffle
<b>Dimensions (HxWxD)</b>	400 x 400 x 446 mm (15.7 x 15.7 x 17.6 in)
<b>Weight (per loudspeaker)</b>	47.40 lbs / (21.5 kg)





# CONCEPT SERIES

Discover more and experience the Concept Series in Augmented Reality (AR) in your home

