

DUAL MONO
POWER
AMPLIFIER

| **M8500S**

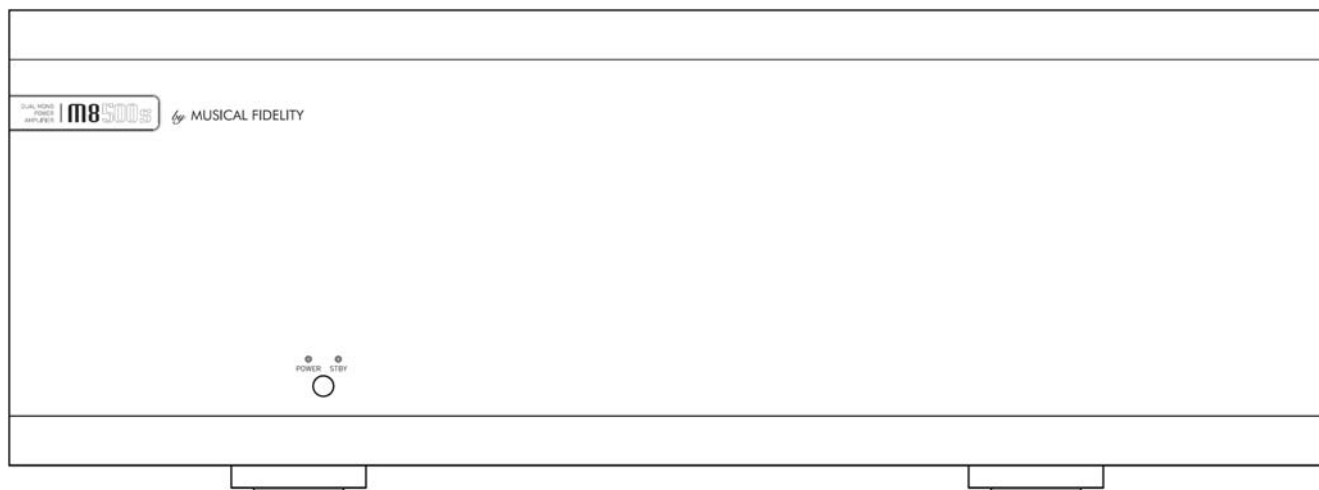

Instructions for use

Thank you for purchasing the Musical Fidelity M8 500S fully balanced dual mono power amplifier.

The M8 500S is designed to be partnered with present and future M8 series products. It is, in fact, based on the Titan design. It features a pair of twin high-current power amplifier sections connected in bridged mono configuration for the absolute best in dynamics and drive capabilities. Two generous over specified power supplies also ensure unsurpassed supply noise filtering, transient handling and massive power reserve possible in a single box power amplifier.

Phase splitting between the two internal amplifiers is achieved using a high performance fully balanced converter circuit with wide flat frequency response uniform in-band characteristics and immeasurably low distortion and noise.

Fully balanced as well as single ended inputs are catered for along with loop outputs for both types, to enable bi-amping etc. Trigger input/output allows the unit to be controlled/controller for switch on/off function.

This combination yields one of the best high-fidelity power amplifiers available at any price.

Used properly and carefully, it should give many years of outstanding musical reproduction.

Dust regularly with a soft duster or soft brush, but be careful when using cleaning or polishing agents - they may harm the surface finish.

If there are any questions about the product or related, please consult the dealer who is there to help and advice.

Section		Page
Safety Information	– Mains plug (UK only) – Modification warning	3
General advice	– Installation precautions	4
Disposal information	– EU disposal information	5
Installation	– Introduction, cleaning, installation, power connections, audio connections	6
Facilities and connections	– Illustrations, main unit front & rear panels	7
Operation	– Single ended (RCA) inputs – Balanced (XLR) inputs – Speaker Bi-wiring – Starting	8 9 10
Problems?	– Basic fault finding	11
Specifications		12
Manual history		13

IMPORTANT! (U.K. only)

This unit is supplied in the U.K. with mains lead fitted with a moulded 13 amp plug. If, for any reason, it is necessary to remove the plug, please remove the fuse holder and dispose of the plug safely, out of reach of children.

It must not be plugged into a mains outlet.

The wires in the mains lead supplied with this appliance are coloured in accordance with the following code:

Green and yellowEarth
Blue..... Neutral
BrownLive

WARNING – This appliance MUST be earthed

As the colours of the wires of the mains lead of this appliance may not correspond with the coloured markings identifying the terminals in the plug, proceed as follows:

- The wire which is coloured green-and-yellow must be connected to the terminal in the plug which is marked with the letter E or coloured green or green-and-yellow, or by the earth symbol: 
- The wire which is coloured brown must be connected to the terminal which is marked with the letter L or coloured red.
- The wire which is coloured blue must be connected to the terminal which is marked with the letter N or coloured black.
- If connecting to a BS1363 plug, a 13 amp fuse must be used.

WARNING:

ANY MODIFICATIONS TO THIS PRODUCT NOT EXPRESSLY APPROVED BY MUSICAL FIDELITY WHO IS THE PARTY RESPONSIBLE FOR STANDARDS COMPLIANCE COULD VOID THE USER'S AUTHORITY TO OPERATE THIS EQUIPMENT.

Installation, Precautions & User Information

This new M8 500S is designed and built to provide trouble-free performance, but as with all electronic devices it is necessary to observe a few precautions:

- This unit features a **BRIDGED** speaker output and should **NOT** be grounded on either speaker output terminal as both red and black speaker terminals are effectively “hot”, i.e. carry high current signals. Please check if using *any* active “sub”, electrostatic, or other non standard potentially grounded speaker types directly connected to the speaker outputs of the M8 500S. Consult speaker manual or supplier if in doubt.
- Heed all warnings shown on the back of the product.
- Only connect the M8 500S to a mains outlet having the same voltage as marked at the back of the unit.
- Always ensure that when disconnecting and reconnecting audio equipment the mains supply is switched off.
- Position the mains lead and signal interconnects where they are not likely to be walked on or trapped by items placed on them.
- Do not use near water, or place water-filled containers on the M8 500S, for example, a flower vase or potted plants. **If water does spill inside, immediately pull out the mains plug from the wall socket and inform the dealer, who should then check the unit before further use. Entry of liquid into the M8 500S is dangerous, and may cause electric shock or fire hazard.**
- Do not place the unit near direct heat sources such as radiators, direct sunlight or other equipment.
- Do not remove any covers or try to gain access to the inside. There are no end-user changeable internal adjustments or components. Refer all service work to an authorised Musical Fidelity agent.
*** Note: Unauthorised opening of the equipment will invalidate any warranty claim.**
- Dust regularly with a soft cloth or soft brush but be careful when using cleaning or polishing agents - they may harm the surface finish.
- The electronics in modern hi-fi equipment is complex and may, therefore, be adversely affected or damaged by lightning. For protection of the audio system during electrical storms, remove the mains plugs.

If after-sales service is required, to help the dealer identify the M8 500S please quote the serial number located on the rear panel of the unit.

**DISPOSAL**

The crossed out wheeled bin label that appears on the back panel of the product indicates that the product must not be disposed of as normal household waste. To prevent possible harm to the environment please separate the product from other waste to ensure that it can be recycled in an environmentally safe manner. Please contact local government office or retailer for available collection facilities.

**DISPOSITION**

La poubelle sur roulettes barrées X, qui apparaît en logo sur le panneau arrière du produit, indique que celui-ci ne doit pas être traité comme un déchet domestique commun. Afin de protéger l'environnement, ce produit électronique devra être géré séparément et donc recyclé selon les nouvelles normes Européennes Rohs concernant les déchets d'appareils électroniques. Prière de contacter les services concernés gouvernementaux ou votre point de vente pour l'élimination et l'enlèvement de déchets électroniques équipés de composants électroniques.

**DISPOSAL**

La etiqueta cruzada hacia fuera del compartimiento que aparece en el panel trasero del producto indica que el producto no se debe reciclar como basura normal de la casa. Para prevenir daños posible al ambiente separe por favor el producto de otras basura para asegurarse de que puede ser reciclada de una manera ambientalmente segura. Entre en contacto por favor a su oficina gubernamental local o a su minorista para las instalaciones disponibles de la colección.

**RIFIUTI**

L'etichetta del cassonetto barrato riportato sul retro dell'apparecchio indica che il prodotto non deve essere smaltito tramite la procedura normale di smaltimento dei rifiuti domestici. Per evitare eventuali danni all'ambiente, separare questo prodotto da altri rifiuti domestici in modo che possa venire riciclato in base alle procedure di rispetto ambientale. Per maggiori dettagli sulle aree di raccolta disponibili, contattate l'ufficio govenativo locale od il rivenditore del prodotto.

**FACHGERECHTE ENTSORGUNG:**

Das auf der Geräterückseite angebrachte Label deutet darauf hin, dass das Produkt nicht mit konventionellem Hauskehricht entsorgt werden darf. Um Schäden und Verschmutzungen an Umwelt und Mensch zu vermeiden, muss das Produkt fachgerecht entsorgt und von anderem Abfall getrennt werden. Wenden Sie sich bei Fragen hierzu an Ihren Fachhändler oder an eine öffentliche Informationsstelle.

**AFVAL**

Het label op de achterzijde van dit apparaat, een afvalbak op wielen met een kruis doorgehaald, geeft aan dat dit apparaat niet samen met gewoon huishoudafval mag worden weggegooid. Om mogelijke schade aan onze leefomgeving te voorkomen dient dit apparaat, gescheiden van gewoon huishoudelijk afval, te worden afgevoerd zodat het op een milieuvriendelijke manier kan worden gerecycled. Neem voor beschikbare inzamelplaatsen contact op met uw gemeentelijke reinigingsdienst of met uw elektronica leverancier.

**HÄVITTÄMINEN**

Yliuksattua jäteastiaa kuvaava tarra tuotteen takalevyssä kertoo, että tuotetta ei saa käsitellä normaalina talousjätteenä. Ympäristön suojelemiseksi on tuote pidettävä erillään muusta jätteestä ja se on kierrätettävä ekologisesti kestävällä tavalla. Ota yhteyttä laitteen myyjään tai Pirkanmaan Ympäristökeskukseen lähimmän kierrätyskeskuksen löytämiseksi.

**AFSKAFNING**

Logoet med en skraldespand med kryds over på bagsiden af apparatet indikerer at dette produkt ikke må kasseres som normal husholdningsaffald. For at forebygge mulig skade på miljøet, bedes De separere dette produkt fra andet affald, og sikre at det bliver genbrugt på en miljørigtig måde. Kontakt venligst de lokale myndigheder eller din forhandler for oplysning om nærmeste tilgængelige opsamlingssted for elektronikaffald.

**ΔΙΑΔΙΚΑΣΙΑ ΑΠΟΡΡΙΨΗΣ**

ΤΟ ΣΗΜΑ ΜΕ ΤΟΝ ΔΙΑΓΕΓΡΑΜΜΕΝΟ ΤΡΟΧΗΛΑΤΟ ΚΑΔΟ ΑΠΟΡΡΙΜΑΤΩΝ ΣΤΗΝ ΠΙΣΩ ΟΨΗ ΤΟΥ ΜΗΧΑΝΗΜΑΤΟΣ

ΔΗΛΩΝΕΙ ΟΤΙ ΤΟ ΠΡΟΙΟΝ ΑΥΤΟ ΔΕΝ ΠΡΕΠΕΙ ΝΑ ΔΙΑΧΕΙΡΙΣΘΕΙ ΣΑΝ ΣΥΝΗΘΙΣΜΕΝΟ ΟΙΚΙΑΚΟ ΑΠΟΒΛΗΤΟ.

ΠΡΟΣ ΑΠΟΦΥΓΗ ΕΝΔΕΧΟΜΕΝΗΣ ΕΠΙΒΑΡΥΝΣΗΣ ΤΟΥ ΠΕΡΙΒΑΛΛΟΝΤΟΣ, ΞΕΧΩΡΙΣΤΕ ΤΟ ΠΡΟΙΟΝ ΑΠΟ ΤΑ ΆΛΛΑ ΑΠΟΡΡΙΜΑΤΑ ΩΣΤΕ ΝΑ ΕΞΑΣΦΑΛΙΣΘΕΙ Η ΑΝΑΚΥΚΛΩΣΗ ΤΟΥ ΜΕ ΤΟΝ ΠΡΕΠΟΝΤΑ ΤΡΟΠΟ.

ΠΑΡΑΚΑΛΟΥΜΕ ΝΑ ΕΠΙΚΟΙΝΩΝΗΣΕΤΕ ΜΕ ΤΗΝ ΤΟΠΙΚΗ ΥΠΗΡΕΣΙΑ ΑΝΑΚΥΚΛΩΣΗΣ Η ΜΕ ΤΟ ΚΑΤΑΣΤΗΜΑ ΑΓΟΡΑΣ ΓΙΑ ΠΕΡΙΣΣΟΤΕΡΕΣ ΛΕΠΤΟΜΕΡΕΙΕΣ.

Introduction

Congratulations on the purchase of the new M8 500S power amplifier. Great attention has been paid to internal layout, isolating each circuit section to prevent possible interaction.

The unit features two monoblock high current bridged amplifiers with generous supplies for the absolute best in transients and dynamics. With their high output current rating, these are enough to drive even the most demanding loudspeakers with ease. Low distortion and very quiet they will deliver all music types exactly as the artist originally intended. The resultant performance achieved by this unit is among the best in the world. It has excellent signal to noise ratio, low distortion, wide bandwidth and dynamic range, with extraordinary resolution and fine detail.

Cleaning

Before cleaning the unit, switch off power at the mains switch and remove the mains plug from the wall socket. Clean the cabinet and remote control unit using a moist cloth. Using solvents, white spirit or thinners is not advised, as they could damage the surface finish.

Installation

Position the M8 500S on a stable, horizontal surface where there is no risk of it being knocked, or subjected to vibration such as from loudspeakers.

Important note:

In normal operation, the unit dissipates a significant quantity of power at all times, and it is important that it is adequately ventilated. The top and bottom are ventilated to allow the smooth flow of heat through the unit. It is therefore not recommended that the unit is enclosed in a cabinet or placed where the ventilation holes are impeded as this could result in excessive heat build-up.

The M8 500S must be protected from humidity – if the unit is moved from a cold place to a warm room, leave the unit for an hour or so to allow sufficient time for the moisture to evaporate.

Power Connections

The M8 500S is supplied with a standard IEC mains cable which plugs into the IEC socket at the back of the unit (see page 7)

Audio Connections

XLR Inputs: Connect any XLR balanced source to balanced analogue inputs (see page 7 for more information). Use good quality fully connected (signals and ground) balanced XLR cables for all XLR signal connections.

The balanced input and outputs sockets are *fully balanced*, i.e. there is signal on both *hot* and *cold* signal terminals. Please ensure for maximum benefit, that any balanced leads used with this product are fully connected both ends and that the cold lead is separate from ground connection. Consult lead manufacturer if there is any doubt.

RCA Inputs: Connect RCA single-ended source to relevant analogue inputs (see page 7 for more information). Use good quality fully connected (signal and ground) coaxial phono cables for all RCA signal connections.

SPEAKER OUTPUTS: Connect loudspeaker(s) to the terminals on the back panel marked as **SPEAKER OUTPUTS**. Take care no short circuits can occur and all connections are firm and stable.

LOOP OUT: loop outputs (XLR and RCA) allow the input signals to be passed on to a second amplifier, or other component. This is useful for example, for bi-amping.

Cables note: Musical Fidelity does not make any interconnecting cables, nor do we endorse any particular third-party manufacturer's cables. If advice is required, please refer to the Musical Fidelity or other local Hi-Fi dealer who can demonstrate suitable quality cable(s) for any particular setup.

Trigger connections

Trigger input: Connect trigger output of controlling device to input socket. Use good quality 3.5mm jack cables (fully connected signal and ground) Unit accepts ± 4 to ± 15 V DC trigger inputs. The M8 500S can then be switched on or off by remote device(s) connected to its trigger input.

Trigger output: Connect trigger input of controlling device to output socket. Use good quality 3.5mm jack cables (fully connected signal and ground). The M8 500S PWR then becomes the main controlling device and its power button will automatically switch on/off all devices thus connected to the trigger output.

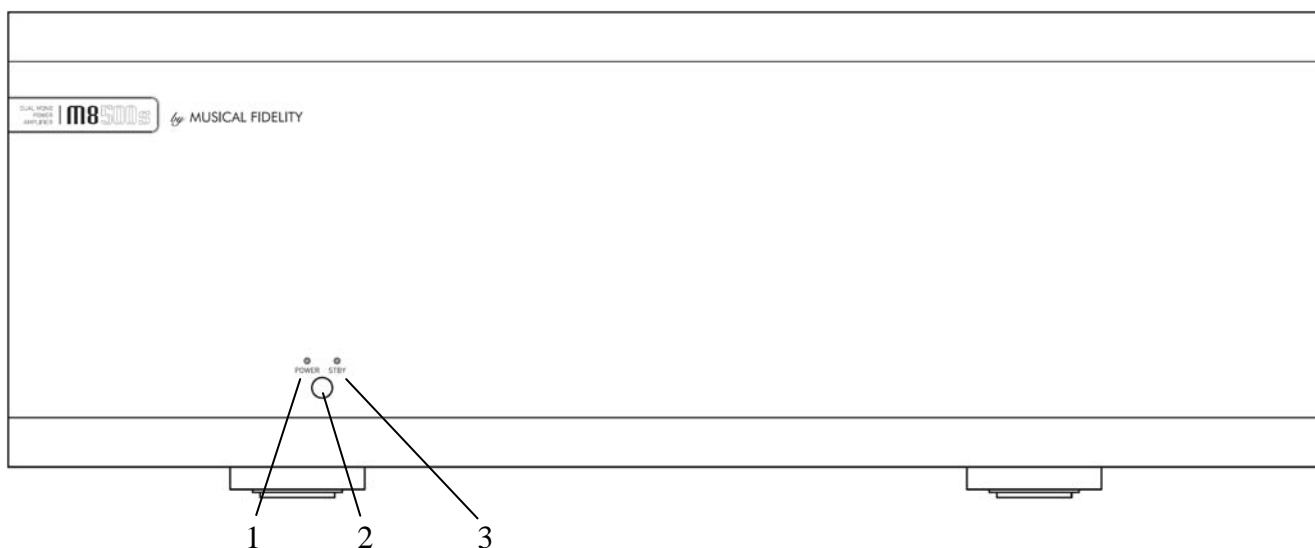

- 1 **POWER LED** blue
- 2 **ON/STANDBY** switch
- 3 **STANDBY LED**

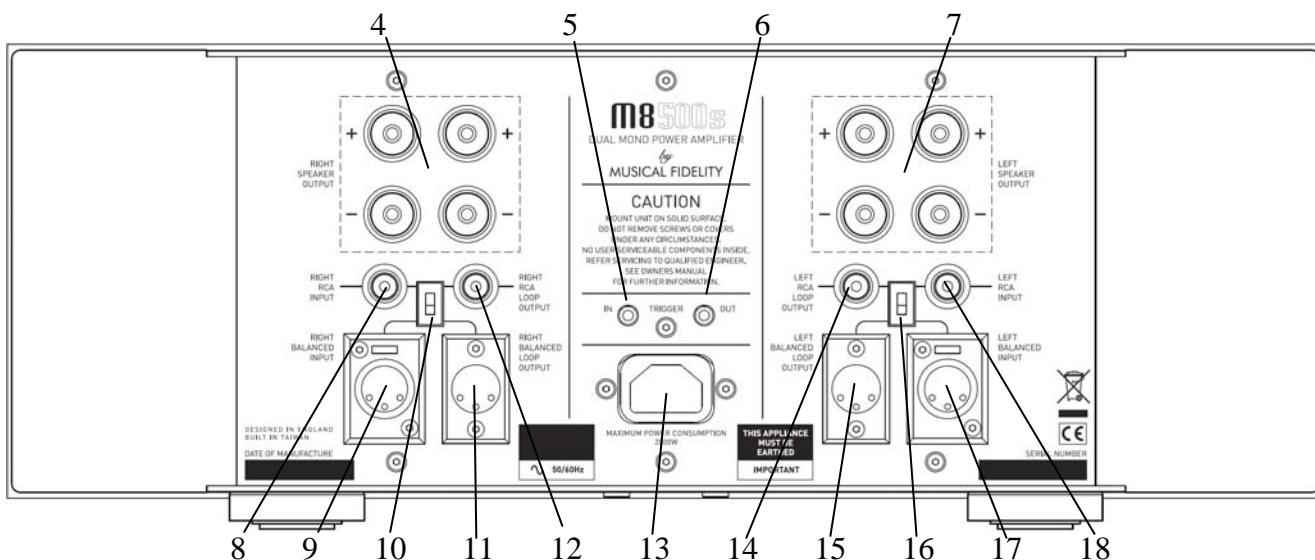

- 4 **RIGHT SPEAKER OUTPUTS** Insulated 4mm banana posts
- 5 **TRIGGER** input jack socket
- 6 **TRIGGER** output jack socket
- 7 **LEFT SPEAKER OUTPUTS** Insulated 4mm banana posts
- 8 **RIGHT RCA** input socket
- 9 **RIGHT BALANCED XLR** (female) input
- 10 **RIGHT RCA/BALANCED** Selector
- 11 **RIGHT BALANCED XLR** (male) loop output
- 12 **RIGHT RCA** loop output socket
- 13 **IEC MAINS INPUT**
- 14 **LEFT RCA** loop output socket
- 15 **LEFT BALANCED XLR** (male) loop output
- 16 **LEFT RCA/BALANCED** Selector
- 17 **LEFT BALANCED XLR** (female) input
- 18 **LEFT RCA** input socket

XLR Balanced input and output lead connections:

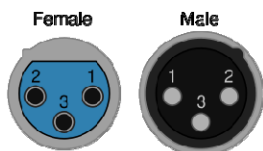

(for reference only, no XLR signal leads supplied)

Pin functions:

- 1 Ground (cable shield)
- 2 Signal + (normal polarity or "hot")
- 3 Signal - (inverted polarity or "cold")

SINGLE-ENDED (RCA) INPUT

To use the RCA **INPUT**, connect RCA source outputs to the **INPUT** RCA sockets. Make sure the **BALANCED/RCA** switch is set for **RCA**.

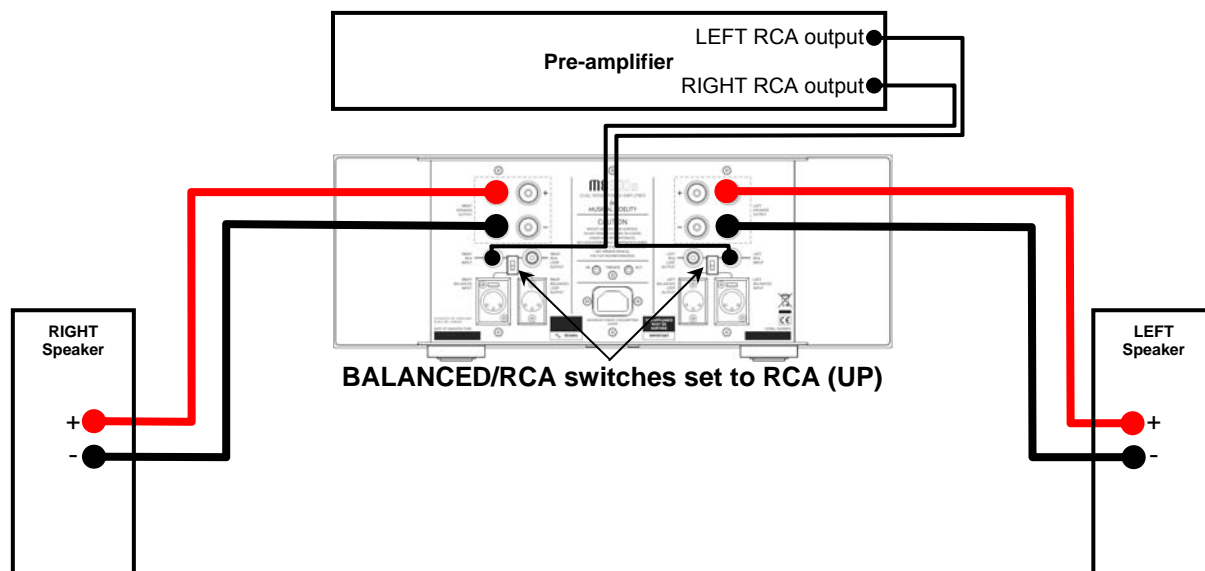

Rear view RCA leads connection diagram.
(Trigger and mains leads omitted for clarity).

Note: On the left hand speaker terminals, the two RED speaker terminals are internally connected together, and the two BLACK speaker terminals are also internally connected together.

Likewise, on the right hand speaker terminals, the two RED speaker terminals are internally connected together, and the two BLACK speaker terminals are also internally connected together.

The diagram above shows the speakers connected to the “outer” output posts. It is therefore also perfectly acceptable to use the inner output posts as *they are exactly the same connections internally*.

IMPORTANT: BALANCED/RCA switch

The **BALANCED/RCA** switches (see page 7) are included to minimise noise when using the unit in RCA mode. In most cases it will operate in **BALANCED** position on RCA inputs with no appreciable audible increase in noise. There is no harm in operating the unit in this way.

However it is important, that if using the XLR (**BALANCED**) input, the switch *must* be set for **BALANCED**. If the switch is not set for **BALANCED** on an XLR input, a 6dB reduction in loudness will occur and the benefits of **BALANCED** operation **will be lost**.

BALANCED (XLR) INPUT

To use the XLR **INPUT**, connect XLR source outputs to the **INPUT** XLR sockets (see page 7). Make sure the **BALANCED/RCA** switches are set for **BALANCED** (down).

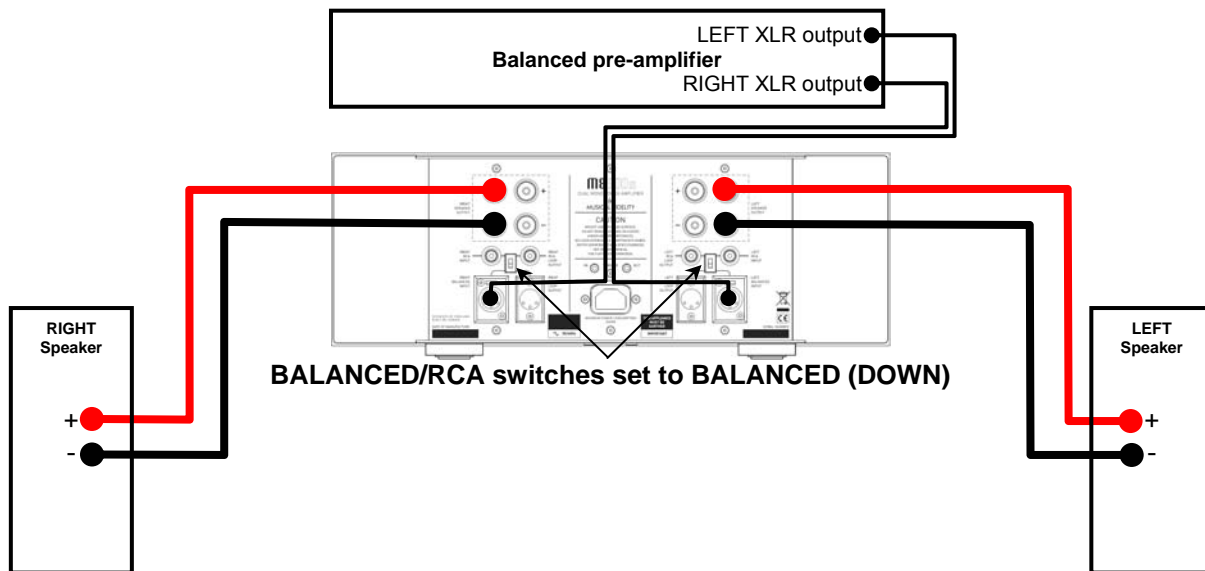

Rear view RCA leads connection diagram.
(Trigger and mains leads omitted for clarity).

Speaker bi-wiring

It is possible to “bi-wire” the outputs with *suitable* speakers. Such speakers must have at least *four* terminals; two for the treble, high frequency (or HF) driver and two more for the bass, low frequency (or LF) driver.

Any “shorting links” between treble and bass input terminals (on the speakers) *must* be removed for maximum benefit. These links normally are visible under the *speaker’s* terminals as gold plates/bars connecting the terminals up in pairs. Please consult speaker manuals/user support for more details.

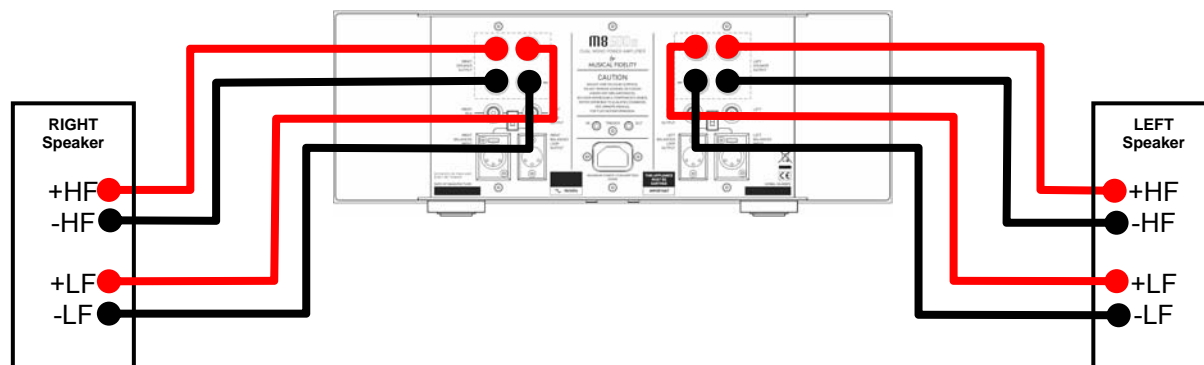

Rear view bi-wiring speaker leads connection diagram.

(Preamp, trigger and mains leads omitted for clarity).

Starting

Once all connections are made, switch on the unit, using the **POWER** button front of the unit. The **MUTE** LED will light. Speaker outputs are muted for about 6 seconds, so no sound will be heard from the speakers. Once the 6 seconds is up the **MUTE** LED goes out, indicating unit is settled, and ready for use.

Basic problem-solving with an amplifier is similar to troubleshooting other electrical or electronic equipment. Always check the most obvious possible causes first, such as the following examples:

Problem	Probable Cause	Remedy
No power when POWER button is pressed.	Mains power plug is not fully inserted into rear socket.	Plug in securely.
No sound	Mute function is still active. Wrong connections between input sources and the unit Speakers not connected, or incorrectly wired	Wait for the MUTE LED to go out. Check audio input lead connections. Check speaker cables.
Sound cut	Loose connection Output overload or short circuit	Check speaker and input connections. Switch unit off. Check speaker connections for shorting strands or wires. When all has been double-checked reduce volume and switch unit back on. N.B. Take great care when bi-wiring or bi-amping that speaker bass and treble linking straps are removed; see speaker manual for more information.
Sound is not precise, lacking in bass and stereo image.	Speakers are connected out of phase, i.e., connections to one speaker (+ and –) are reversed.	Ensure speakers are connected with same polarity at amplifier and speaker ends.
Hum.	Audio connector plug not fully pushed in Cable Fault Unsuitable cable (e.g. cable grounds not connected)	Insert plug securely. Check cable is connected at both ends. N.B. Some esoteric cables have internal wiring intentionally disconnected/modified. For best results on all inputs analogue AND digital, please use good quality screened coax; signal and screens both separately connected at both ends.
No audio output, or too low level output.	Incorrect or missing connections	Check connections and make sure they are secure.

If none of these actions affect a cure, please contact the dealer, or an authorised Musical Fidelity service agent. Remember; never open the case of the M8 500S, as this will invalidate the guarantee.

Output

Power	500 Watts per channel into 8 Ohms (27 dBW)
Voltage	63.4 Volts RMS, 20Hz to 20 kHz; onset of clipping (179 Volts peak-to-peak)
Current peak-to-peak	200 Amps
Damping factor	>330
Output devices	6 pairs per channel

Line input

THD+N	<0.007% typical, 20 Hz to 20 kHz
Signal / noise ratio	>120 dB 'A'-weighted
Input impedance	50k Ohms
Frequency response	+0, -1dB, 10Hz to 80 kHz

Connections

Line level inputs	1 pair line level XLR (fully balanced) connectors 1 pair line level RCA connectors
Line level outputs	1 pair line level XLR (balanced) connector loop output 1 pair line level RCA connector loop output
Speaker outputs	2 sets of 2 pairs 4mm banana plug/binding posts
Trigger input	3.5mm (1/8") mono jack ± 4.5 to ± 15 V DC
Trigger output	3.5mm (1/8") mono jack +12V DC

Power requirement

Mains voltages	115/230VAC 50/60Hz (factory pre-set) 100VAC 50/60Hz (alternative)
Consumption	0.25 Watts standby (Orange LED lit) 150 Watts on, idle (Blue LED lit, no signal output) 2000 Watts maximum (Blue LED lit, full power output)

Weight

Unit only, unboxed	29 kg	(63 $\frac{3}{4}$ lbs)
In shipping carton	34.5 kg	(76 lbs)

Dimensions

Width	440 mm	(17 $\frac{1}{3}$ ")
Height (including feet)	160 mm	(6 $\frac{1}{3}$ ")
Depth (front to back) including terminals	460 mm	(18 $\frac{1}{8}$ ")

Standard accessories

IEC type mains lead (10-Amp type)

Musical Fidelity reserves the right to make improvements which may result in specification or feature changes without notice. E&OE.



RELEASE	DATE	CHANGES
Issue 1	30 th October 2013	1st issue